

Revizyonlar-Revisions				
No	Tarih-Date	Açıklama-Description	İsim-Name	İmza-Signature

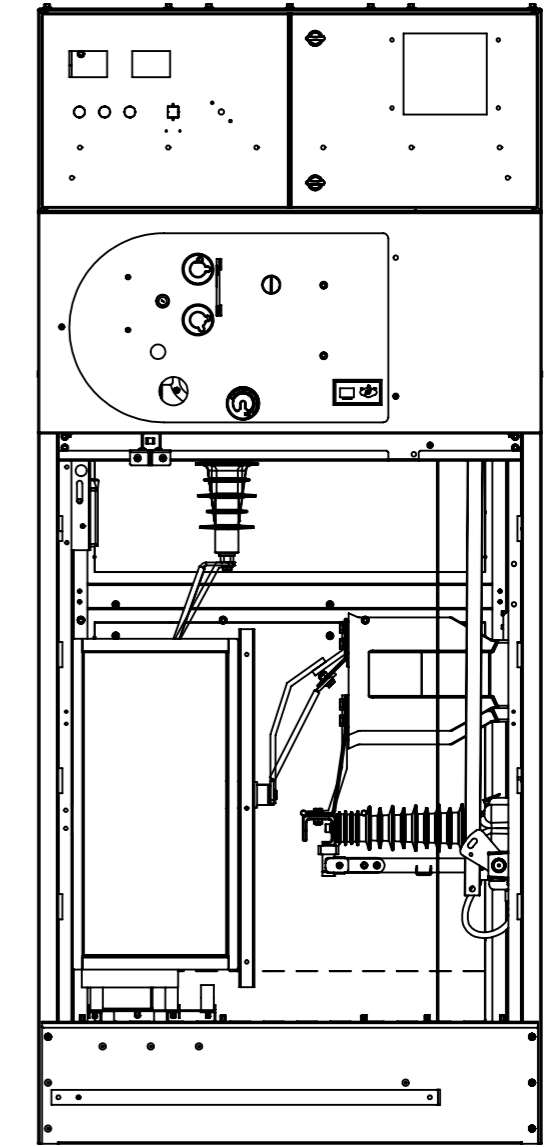
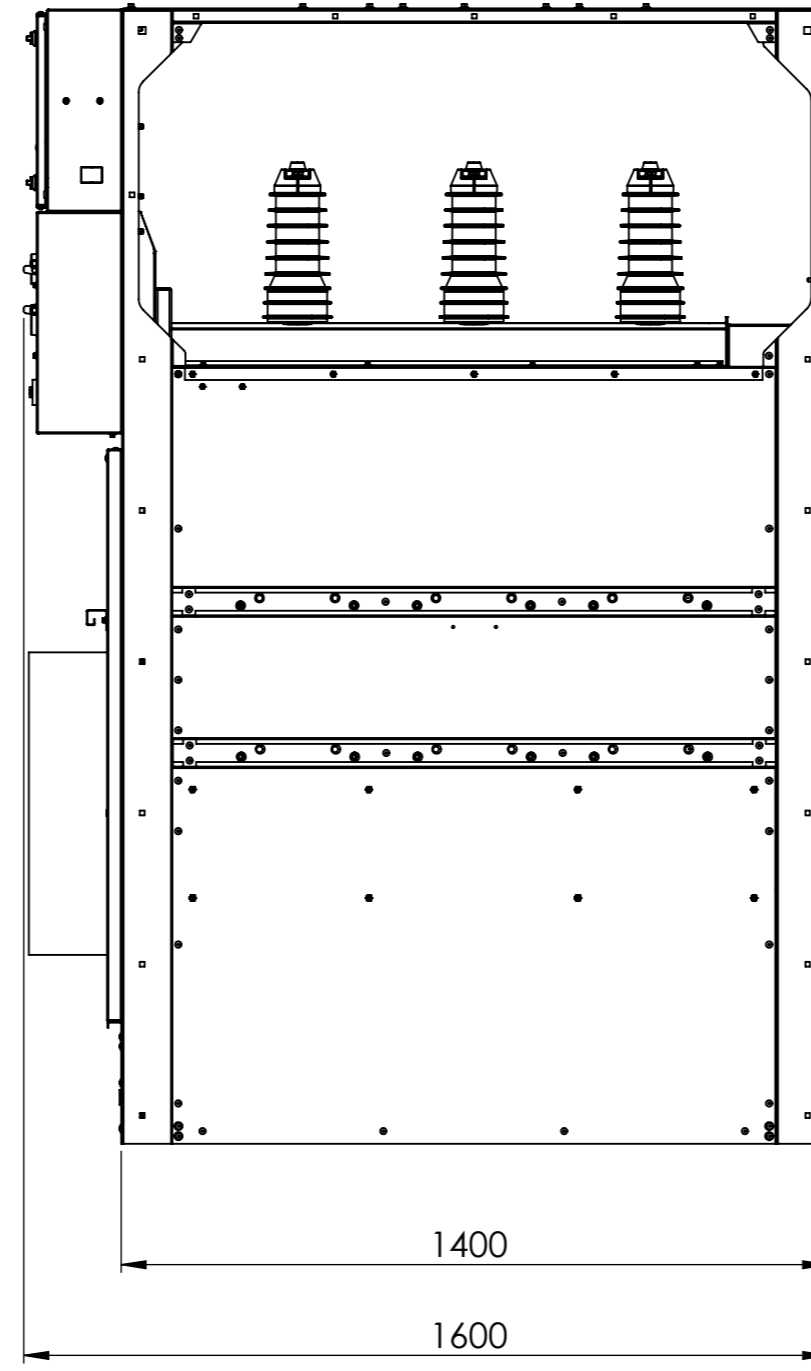
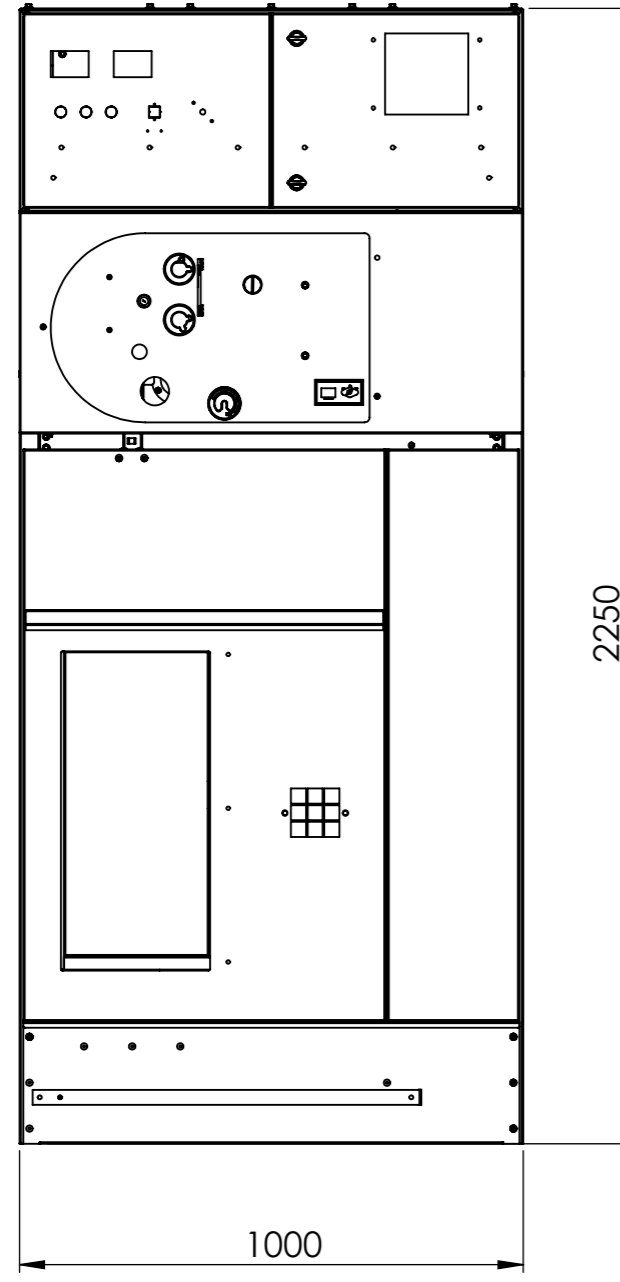

NOTLAR	NOTES
<p>1. AKSİ BELİRTİLMEDİKÇE;</p> <p>1.1 ÖLÇÜLER;</p> <ul style="list-style-type: none"> - MİLMETREDİR. - KAPLAMA SONRASIDIR. - TOLERANS SINIFI ISO 2768-mH <p>1.2 YÜZEY PÜRÜZLÜLÜĞÜ Ra 3,2</p> <p>1.3 METRİK DİŞLER DİN 376'YA UYACAKTIR.</p> <p>1.4 KEŞKİN KOŞELERE İZİN VERİLMEZ.</p> <p>1.5 KOŞELERE 0,2x45° PAH KIRILACAKTIR.</p> <p>1.6 ÇAFAKLARA İZİN VERİLMEZ.</p> <p>2. KALİTE TEMİN İSTEKLERİ</p> <p>2.1 MALZEME SERTİFİKASI</p> <p>2.2 KAPLAMA SERTİFİKASI</p> <p>2.3 ○ İLE İŞARETLENMİŞ ÖLÇÜLER</p> <p>2.4 GEOMETRİK ÖLÇÜ TOLERANSLAR</p> <p>2.5 BELİRTİLEN EK İSTEKLER</p>	<p>1. UNLESS OTHERWISE SPECIFIED;</p> <p>1.1 DIMENSIONS ARE;</p> <ul style="list-style-type: none"> - IN MILLIMETERS. - AFTER SURFACE OPERATIONS - I.A.W. ISO 2768-mH <p>1.2 SURFACE ROUGHNESS Ra 3,2</p> <p>1.3 METRIC THREADS ARE I.A.W. DİN 376</p> <p>1.4 SHARP CORNERS ARE NOT ALLOWED</p> <p>1.5 BROKEN EDGES to 0,2x45° CHAMFER</p> <p>1.6 BURRS ARE NOT ALLOWED</p> <p>2. QUALITY ASSURANCE PROVISIONS</p> <p>2.1 CERTIFICATE OF MATERIAL</p> <p>2.2 CERTIFICATE OF SURFACE OPERATIONS</p> <p>2.3 DIMENSIONS GIVEN IN ○</p> <p>2.4 GEOMETRIC DIMENSIONS & TOLER.</p> <p>2.5 SUPPLEMENTARY PROVISIONS</p>

Kaplama - Coating:	Durum-Status	TASARIM AŞAMASINDA	Tarih-Date	İmza-Signature	
Kalınlık-Thickness:	Tasarlayan-Designed By				
Boya-Paint:	Kontrol-Checked By				SAP No
Yüzey Alanı-Surface Area:	Çizen-Drawn By				Sayfa-Sheet 1/1 A3
mm ²	Onay-Approved By				Ölçek-Scale 1:50
Ağırlık-Weight:	Malzeme-Material:	Parça Adı-Part Name		SFA-AIS36-B_ABB	
gr.		Parça No-Part Number			