

Revizyonlar-Revisions				
No	Tarih-Date	Açıklama-Description	İsim-Name	İmza-Signature

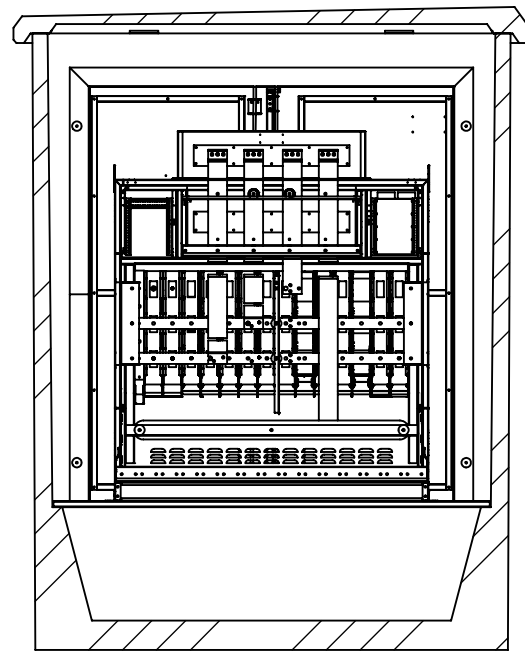

SECTION I-I
SCALE 1 : 40

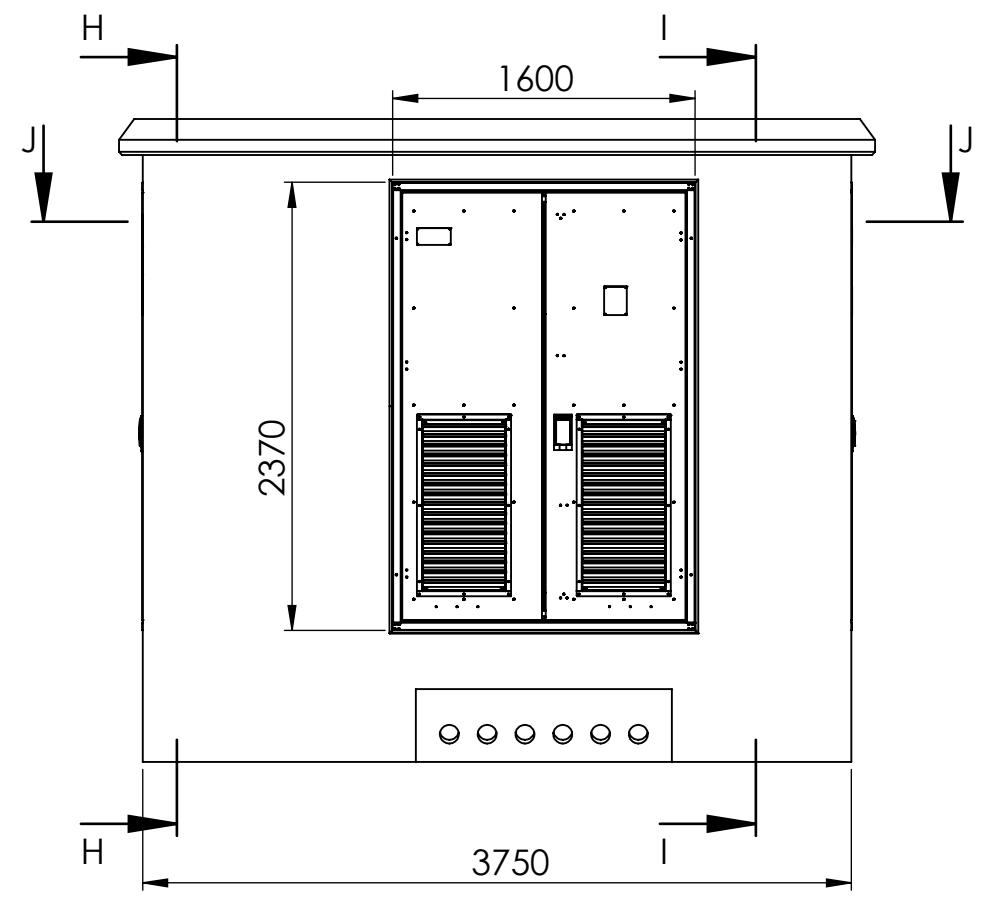
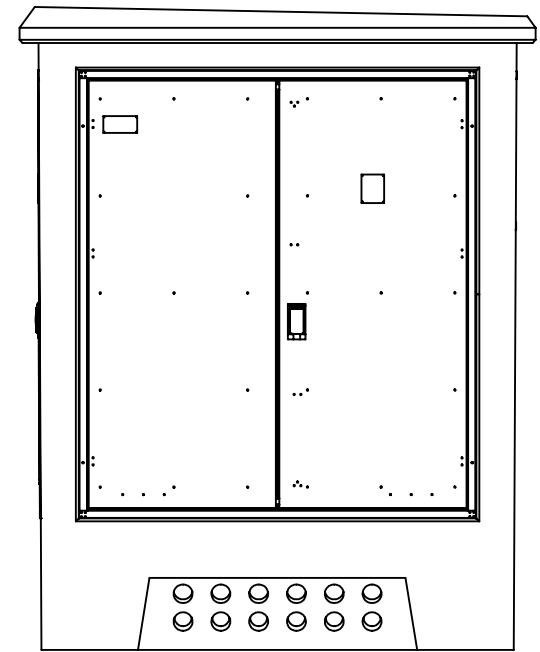

SECTION H-H
SCALE 1 : 40

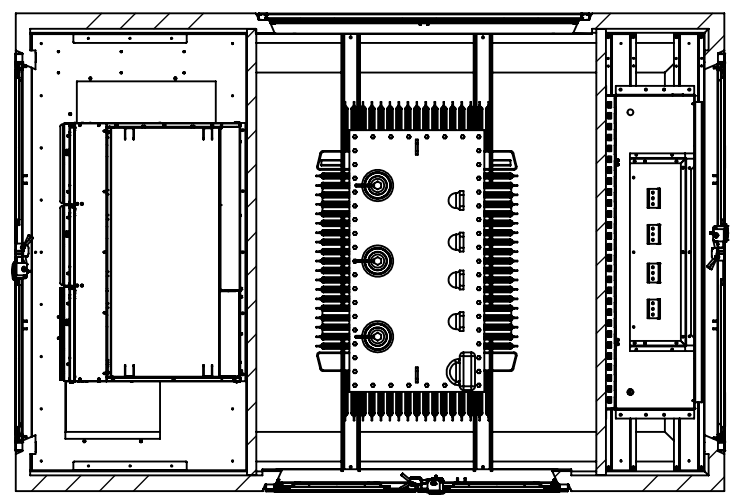
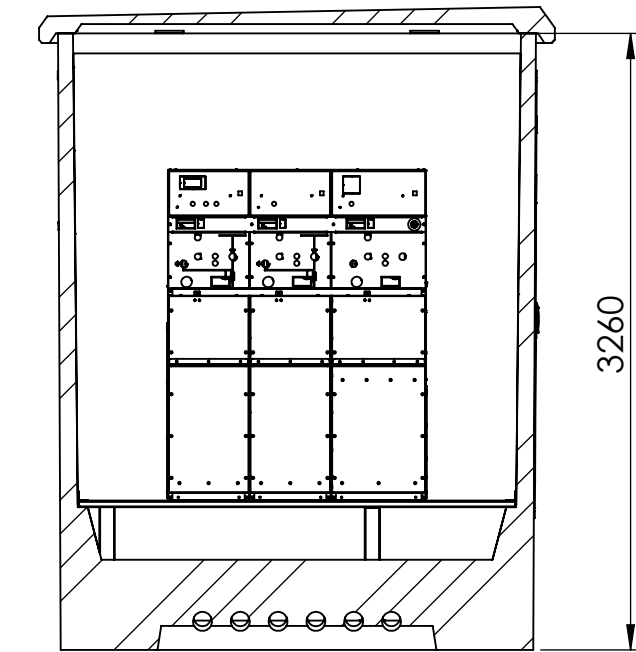

SECTION J-J
SCALE 1 : 40

NOTLAR	NOTES
1. AKSİ BELİRTİLMEDİKÇE; 1.1 ÖLÇÜLER; - MİLMETREDİR. - KAPLAMA SONRASIDIR. - TOLERANS SINIFI ISO 2768-mH 1.2 YÜZEY PÜRÜZLÜĞÜ Ra 3,2 1.3 METRİK DİŞLER DİN 376'YA UYACAKTIR. 1.4 KEŞKİN KOŞELERE İZİN VERİLMEZ. 1.5 KOŞELERE 0,2x45° PAH KIRILACAKTIR. 1.6 ÇAFAKLARA İZİN VERİLMEZ. 2. KALİTE TEMİN İSTEKLERİ 2.1 MALZEME SERTİFİKASI 2.2 KAPLAMA SERTİFİKASI 2.3 İLE İŞARETLENMİŞ ÖLÇÜLER 2.4 GEOMETRİK ÖLÇÜ TOLERANSLAR 2.5 BELİRTİLEN EK İSTEKLER	1. UNLESS OTHERWISE SPECIFIED; 1.1 DIMENSIONS ARE; - IN MILIMETERS. - AFTER SURFACE OPERATIONS - I.A.W. ISO 2768-mH 1.2 SURFACE ROUGHNESS Ra 3,2 1.3 METRIC THREADS ARE I.A.W. DİN 376 1.4 SHARP CORNERS ARE NOT ALLOWED 1.5 BROKEN EDGES to 0,2x45° CHAMFER 1.6 BURRS ARE NOT ALLOWED 2. QUALITY ASSURANCE PROVISIONS 2.1 CERTIFICATE OF MATERIAL 2.2 CERTIFICATE OF SURFACE OPERATIONS 2.3 DIMENSIONS GIVEN IN \varnothing 2.4 GEOMETRIC DIMENSIONS & TOLER. 2.5 SUPPLEMENTARY PROVISIONS

Kaplama - Coating:	Durum-Status	TASARIM AŞAMASINDA	Tarih-Date	İmza-Signature	SFA ELECTRIC
Kalınlık-Thickness:	Tasarlayan-Designed By				
Boya-Paint:	Kontrol-Checked By				SAP No
Yüzey Alanı-Surface Area:	Çizen-Drawn By				Sayfa-Sheet 2/2 A3
mm ²	Onay-Approved By				Ölçek-Scale 1:50
mm ²	Malzeme-Material:	Parça Adı-Part Name			3750_BETON_KOSK
mm ²	Ağırlık-Weight: "SW-Mass@Part.SLDPRT"	Parça No-Part Number			