

Revizyonlar-Revisions				
No	Tarih-Date	Açıklama-Description	İsim-Name	İmza-Signature

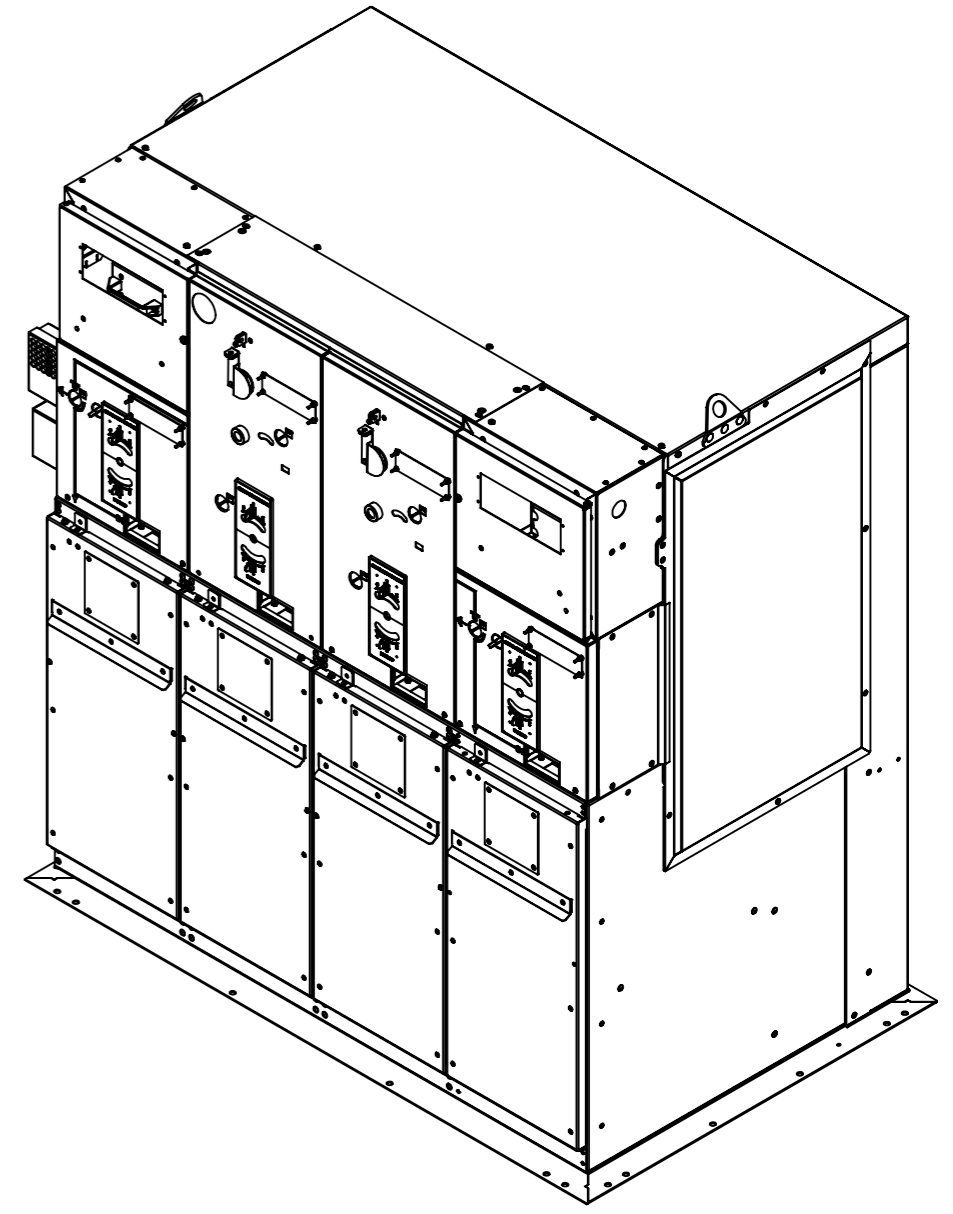
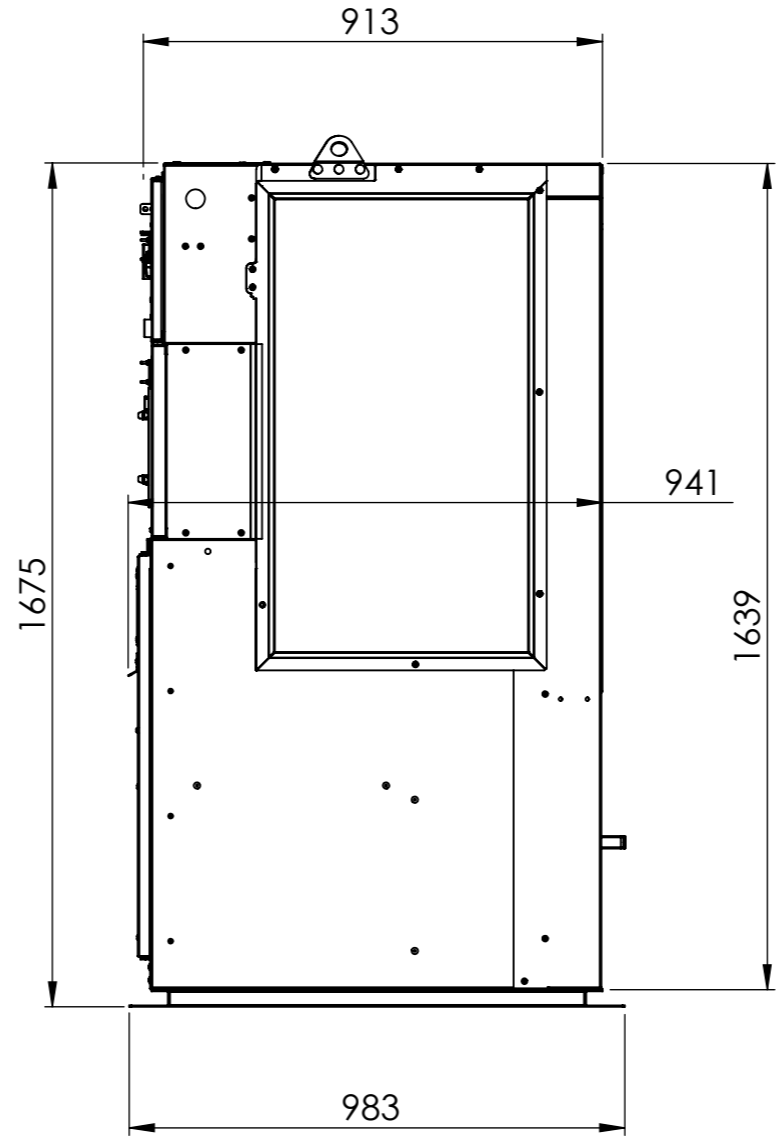
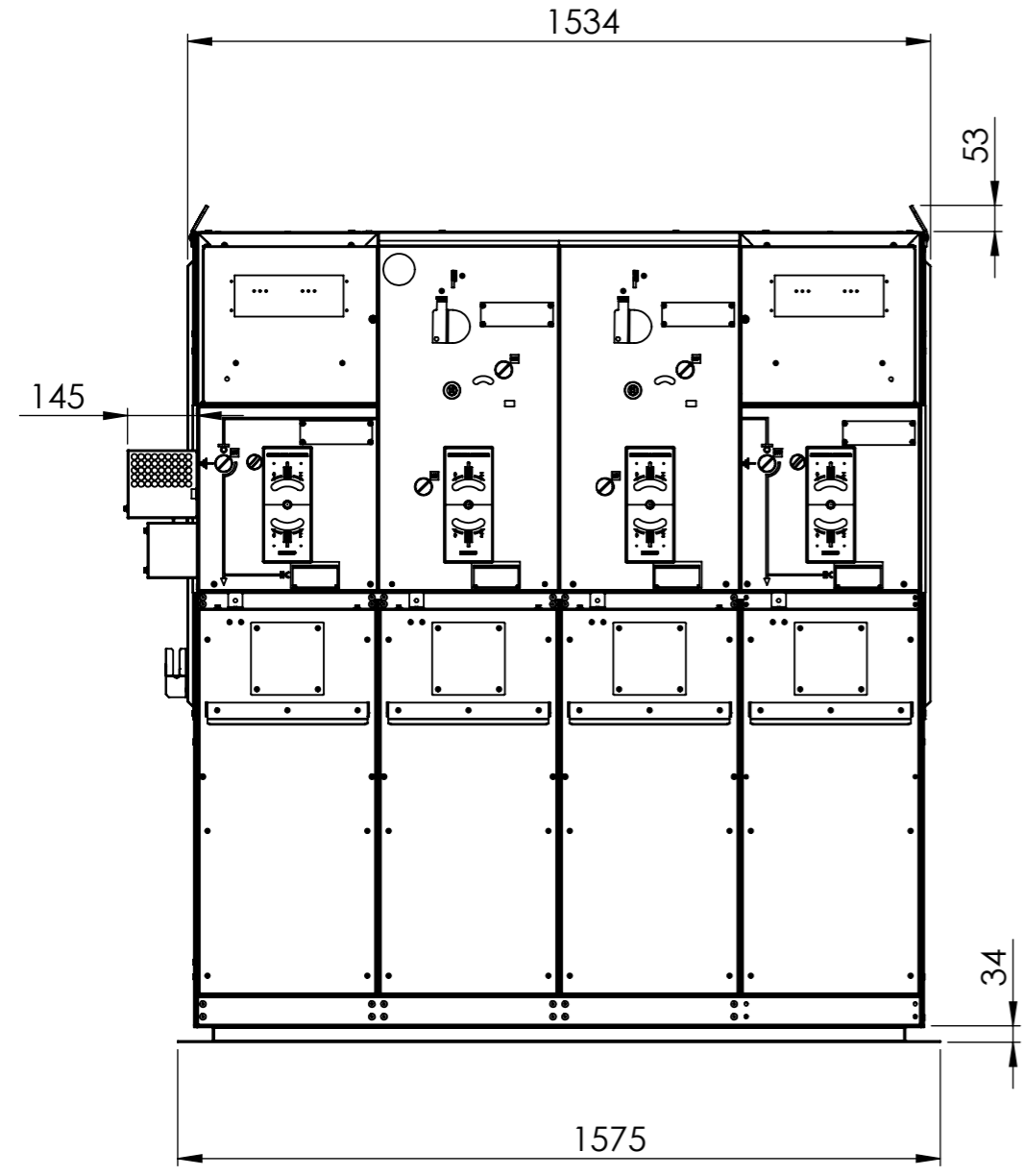

NOTLAR	NOTES
<p>1. AKSİ BELİRTİLMEDİKÇE; 1.1 ÖLÇÜLER; - MİLMETREDİR. - KAPLAMA SONRASIDIR. - TOLERANS SINIFI ISO 2768-mH 1.2 YÜZEY PÜRÜZLÜĞÜ Ra 3,2 1.3 METRİK DİŞLER DİN 376'YA UYACAKTIR. 1.4 KEŞKİN KOŞELERE İZİN VERİLMEZ. 1.5 KOŞELERE 0,2x45° PAH KIRILACAKTIR. 1.6 ÇAPAKLARA İZİN VERİLMEZ. 2. KALİTE TEMİN İSTEKLERİ 2.1 MALZEME SERTİFİKASI 2.2 KAPLAMA SERTİFİKASI 2.3 İLE İŞARETLENMİŞ ÖLÇÜLER 2.4 GEOMETRİK ÖLÇÜ TOLERANSLAR 2.5 BELİRTİLEN EK İSTEKLER</p>	<p>1. UNLESS OTHERWISE SPECIFIED; 1.1 DIMENSIONS ARE; - IN MILIMETERS. - AFTER SURFACE OPERATIONS - I.A.W. ISO 2768-mH 1.2 SURFACE ROUGHNESS Ra 3,2 1.3 METRIC THREADS ARE I.A.W. DIN 376 1.4 SHARP CORNERS ARE NOT ALLOWED 1.5 BROKEN EDGES to 0,2x45° CHAMFER 1.6 BURRS ARE NOT ALLOWED 2.QUALITY ASSURANCE PROVISIONS 2.1 CERTIFICATE OF MATERIAL 2.2 CERTIFICATE OF SURFACE OPERATIONS 2.3 DIMENSIONS GIVEN IN 2.4 GEOMETRIC DIMENSIONS & TOLER. 2.5 SUPPLEMENTARY PROVISIONS</p>

Kaplama - Coating:	Durum-Status	TASARIM AŞAMASINDA	Tarih-Date	İmza-Signature	
Kalınlık-Thickness:	Tasarlayan-Designed By				
Boya-Paint:	Kontrol-Checked By				SAP No
Yüzey Alanı-Surface Area:	Çizen-Drawn By				Sayfa-Sheet 1/1 A3
85616018.99 mm ²	Onay-Approved By				Ölçek-Scale 1:50
Ağırlık-Weight: 19MR0315-SFA INDOOR	Malzeme-Material:	Parça Adı-Part Name			
SW-Mass@Part.SLDPR1	Material <not specified>	Parça No-Part Number			