

Revizyonlar-Revisions				
No	Tarih-Date	Açıklama-Description	İsim-Name	İmza-Signature

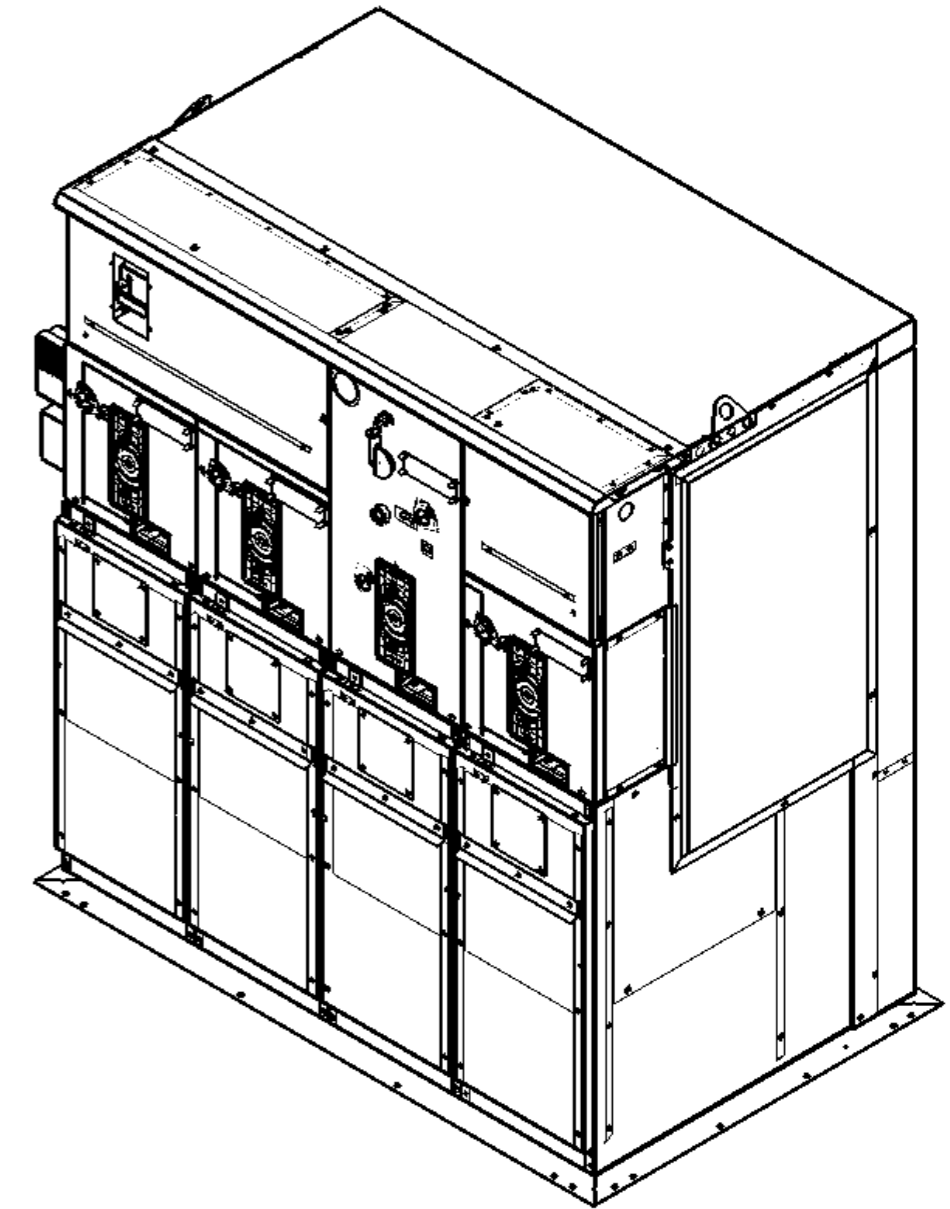
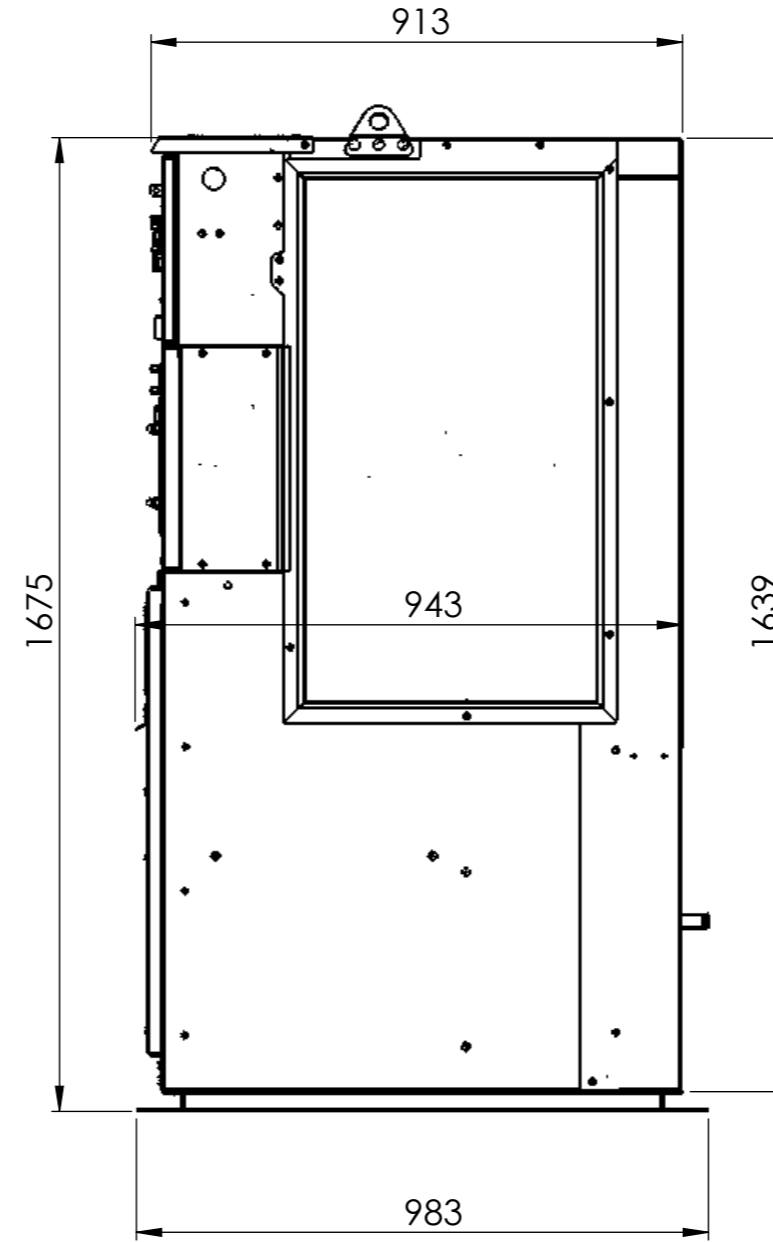
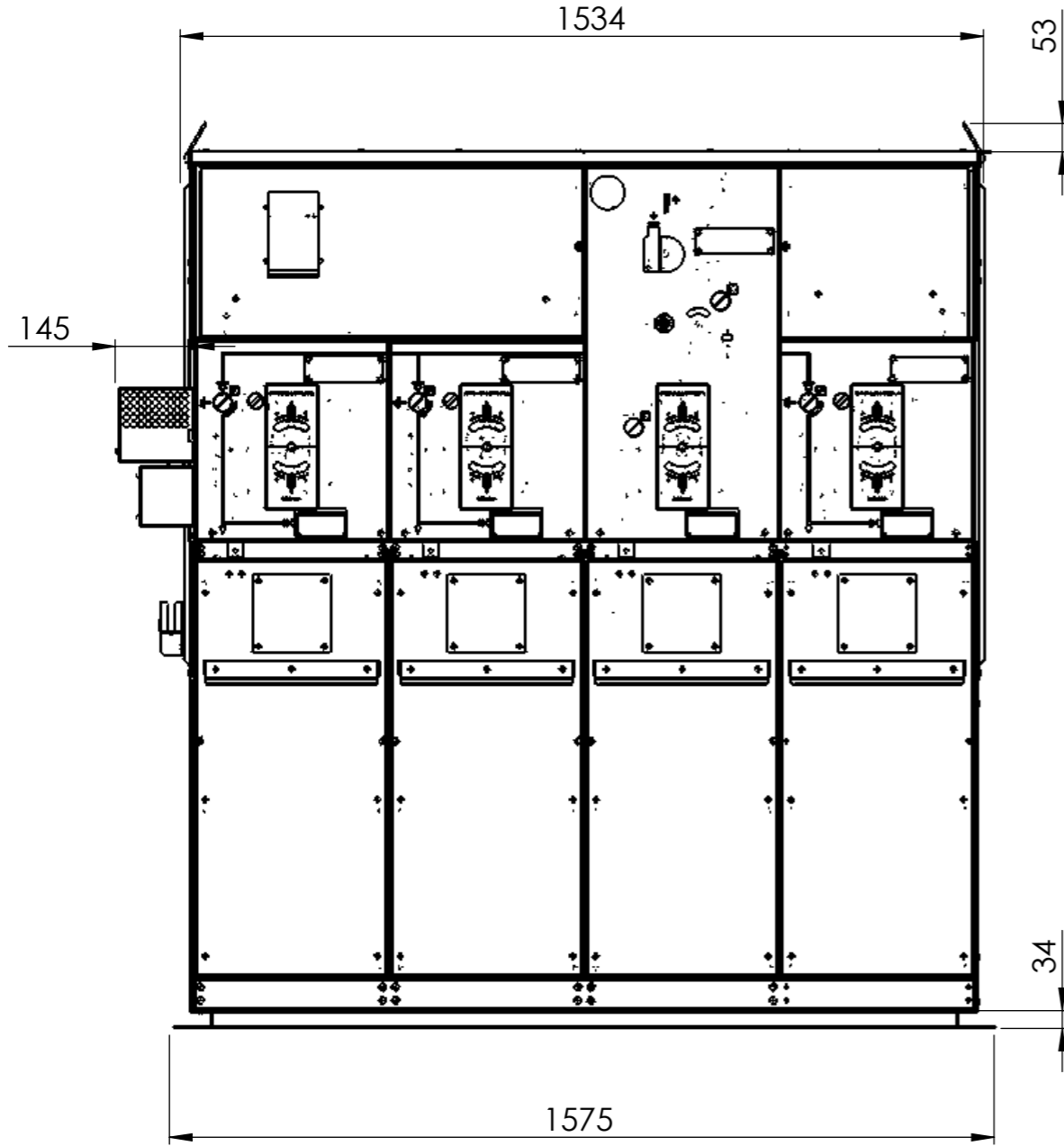

NOTLAR

- AKŞİ BELİRTİLMEDİKÇE:
 - ÖLÇÜLER:
 - MİLMİTREDİR.
 - KAPLAMA SONRASIDIR.
 - TOLERANS SINIFI ISO 2768-mH
 - YÜZEY PÜRÜZLÜLÜĞÜ Ra 3.2
 - METRİK DİŞLER DİN 376'YA UYACAKTIR.
 - KESKİN KOŞELERE İZİN VERİLMEZ.
 - KOŞELERE 0.2x45° PAH KIRILACAKTIR.
 - ÇAPAKLARA İZİN VERİLMEZ.
- KALİTE TEMİN İSTEKLERİ
 - MALZEME SERTİFİKASI
 - KAPLAMA SERTİFİKASI
 - İLE İŞARETLENMİŞ ÖLÇÜLER
 - GEOMETRİK ÖLÇÜ TOLERANSLAR
 - BELİRTİLEN EK İSTEKLER

NOTES

- UNLESS OTHERWISE SPECIFIED;
 - DIMENSIONS ARE:
 - IN MILLIMETERS.
 - AFTER SURFACE OPERATIONS
 - I.A.W. ISO 2768-mH
 - SURFACE ROUGHNESS Ra 3.2
 - METRIC THREADS ARE I.A.W. DIN 376
 - SHARP CORNERS ARE NOT ALLOWED
 - BROKEN EDGES to 0.2x45° CHAMFER
 - BURRS ARE NOT ALLOWED
- QUALITY ASSURANCE PROVISIONS
 - CERTIFICATE OF MATERIAL
 - CERTIFICATE OF SURFACE OPERATIONS
 - DIMENSIONS GIVEN IN İLE
 - GEOMETRIC DIMENSIONS & TOLER.
 - SUPPLEMENTARY PROVISIONS

Kaplama - Coating:

Kalınlık-Thickness:
Boya-Paint:Yüzey Alanı-Surface Area:
82677149.80 mm²

Durum-Status

Tasarlayan-Designed By

Kontrol-Checked By

Çizen-Drawn By

Onay-Approved By

Malzeme-Material:

Material <not specified>

Ağırlık-Weight:

TASARIM AŞAMASINDA

Tarih-Date

İmza-Signature

Parça Adı-Part Name

Parça No-Part Number

S19MR0315-SFA SSBS INDOOR

SFA ELECTRIC

SAP No

Sayfa-Sheet 1/1 A3

Ölçek-Scale 1:50