

Welcome

CORPORATE

About Us

SFA Electromechanical Electricity Industry and Trade Inc. (shortly **SFA ELECTRIC**) was established in 2015 to operate in the electromechanical sector. The company's founding partners have more than 40 years of experience in the sector and the company carries out its production activities in the factory located in Ankara Sincan Organized Industrial Zone on an area of 17.500m2.

SFA ELECTRIC develops its products in R & D department according to the relevant national / international standards and technical specifications. The developed products are taken to the mass production stage after successfully completing the relevant type tests in accredited laboratories. ISO Quality Standards are followed in production.

SFA ELECTRIC; as an international firm, has a rapid growth trend and thanks to strong ex activities SFA ELECTRIC has succeeded to take part in the "2016 & 2018 top exporters" in the sector. Achieving higher levels in this ranking with new products and new markets is among the targets of the Company.

Mission

As **SFA ELECTRIC**, our mission is to provide medium-voltage switchgear to users in a cost-effective way by producing the highest quality.

Vision

It is to be a dynamic, innovative and differentiating brand in the global market for the development and production of medium voltage switchgear used in electricity transmission and distribution.

Environmental Policy

As a company that is responsible for its values, we promise to protect the environment and to comply with ISO 14001 standards.

In this context, we have constructed our business in a way that is more efficient and more useful to humanity and our world in the examination of the energy of societies.

We support environmentally friendly products and the reduction of carbon dioxide emissions. In this sense, we follow the rules and support activities that reduce global warming. In this context, we donate to **TEMA** and **WWF** institutions for every order we receive in accordance with our understanding of giving back to nature and our corporate strategy.



SFA ELECTRIC PRODUCTS

01 > SF6 Gas Insulated Switchgears and Controlgears (Cubicles) (≤ 36 kV)

02 > Switching Devices (≤ 36 kV)

- Vacuum Circuit Breakers,
- Circuit Breakers with SF₆,
- Switch-Disconnectors with SF₆,
- Switch+Fuse Combinations with SF₆,
- Earthing switches

03 > Air Insulated Metal Enclosed Switchgears And Controlgears (Cubicles) (≤ 36 kV)

04 > Seperable Cable Connectors

05 > Transformer Substations (≤ 1600 kVA)

- Concrete Enclosure
- Metal Sheet Steel Enclosure,

06 > Special Products

- Mobile Substations
- Invertor Kiosks (Concrete Enclosure)
- Invertor Kiosks (Container type)

CONTENTS

01	>	GENERAL	06
02	>	CONSTRUCTIONAL FEATURES	07
03	>	TYPES	08>19
	∨		
01	>	COMPACT TYPE RING MAIN UNIT [SSF]	08
02	>	COMPACT TYPE RING MAIN UNIT [SSB]	09
03	>	CUBICLE WITH SWITCH-DISCONNECTOR	10
04	>	CUBICLE WITH SWITCH-FUSE COMBINATION FOR TRANSFORMER PROTECTION	11
05	>	CUBICLE WITH VACUUM CIRCUIT BREAKER	12
06	>	CUBICLE WITH BUS-BAR COUPLING	13
07	>	METERING (CT+VT) CUBICLE WITH SWITCH-DISCONNECTOR	14
08	>	METERING (CT+VT) CUBICLE WITH VACUUM CIRCUIT BREAKER	15
09	>	METERING (CT+VT) CUBICLE WITH SWITCH-FUSE COMBINATION	16
10	>	VOLTAGE METERING CUBICLE WITH SWITCH-DISCONNECTOR	17
11	>	CABLE RISING CUBICLE	18
12	>	CUBICLE WITH VACUUM CIRCUIT BREAKER (CT+VT)	19
04	>	EQUIPMENTS	20>21
05	>	CONTROL PANEL	22>23
06	>	HV CABLE CONNECTIONS	24
07	>	SIDE EXTENSIONS	25

08	> HV FUSE	26
09	> ACCESSIBILITY AND COMPLIANCE WITH STANDARDS	27
10	> DIMENSIONS, SINGLE LINE DIAGRAMS AND VIEWS	28>39
11	> PACKING AND TRANSPORT	40
12	> INSTALLATION & COMMISSIONING	41
13	> DESIGN	42
14	> QUALITY CONTROL	43
15	> TECHNICAL FEATURES	44>49

01

36kV

SFA-RM

SF6
GAS INSULATED RING MAIN UNITS

GENERAL

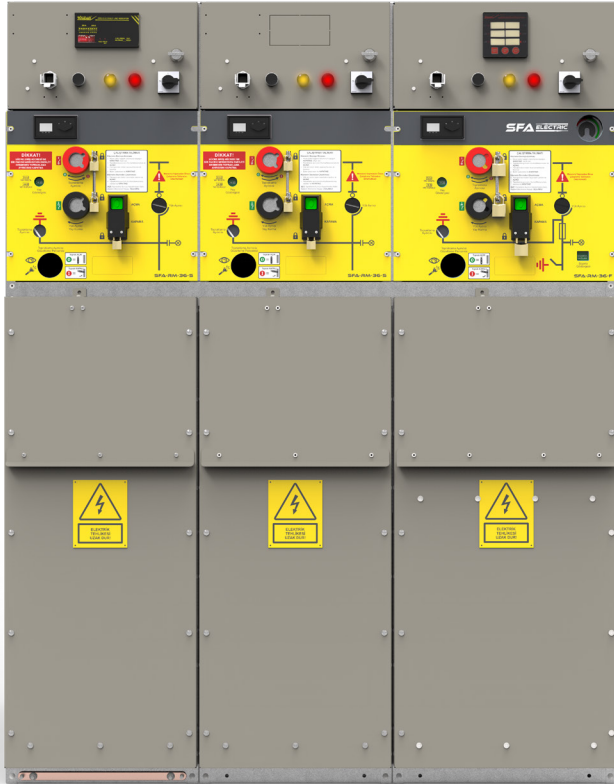

Key Features;

- Compact design and type tested,
- High level operator safety, high level operation reliability,
- Lower filling SF6 gas pressure (1,1 bar, abs.), lower minimum operating SF6 gas pressure (1,05 bar. abs.)
- Hermetically sealed pressure system, leakage rate less than % 0.5 per year,
- Resistant to pollution, insensitive to humidity and altitude,
- Modular and compact type (extensible and non-extensible)
- The lower maintenance cost
- Suitable for remote control and monitoring,
- Comply with relevant IEC and EN standards

Safety;

- Withstand to internal arc due to durable design against thermal and dynamic effects,
- Possibility to check visually the position of Earthing Switch (CLOSE or OPEN) through the surveillance window on the front pane.
- Consecutive interlocking systems prevent incorrect operation. Access to the cable compartment and fuse compartment is only possible if the related earthing switch/switches is on the earthed position.

Fields of Major Application;

- Secondary Electricity Distribution networks
- MV/LV Distribution Transformer Substation,
- Wind Power Plants,
- Sun Power Plants,
- Areas where industrial pollution is high
- High humidity areas
- Hospitals, hotels, shopping centers

COMPACT type RMU's can be manufactured extensible either both side or only left/right side.



Applied standard	: IEC 62271-200
Loss of the Service Continuity	: LSC2
Partition	: PM
Internal arc	: IAC A (FL) IAC A (FLR)*

**for modular types*

SFA-RM36 Cubicles consist of five compartments;

- Main Busbar and Switching Compartment,
- HV Cable Connection Compartment,
- HV Fuse Compartment
- Operating Mechanism Compartment
- LV Panel Compartment

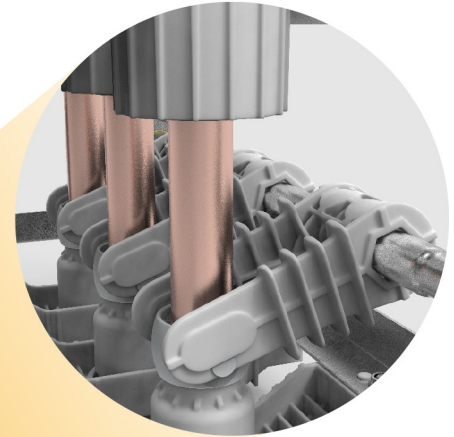

Earthing Switch

OPEN

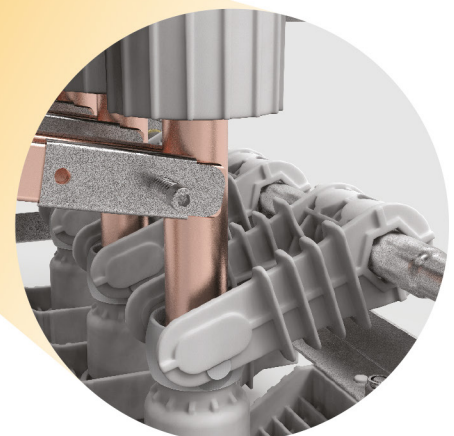

Earthing Switch

CLOSED

After operation, it is possible to check the position of earthing switch (closed or not) via a surveillance window visually.

**Standard Equipments**

2 (two) feeders with switch-disconnector;

- Switch-disconnector
(three-positioned, OPEN-CLOSED-EARTHED)
- Integrated capacitive voltage presence indicator system (VPIS),
- Operating mechanism (type MO18)
- Plug-in bushings
(Interface: C, Contact type: Bolted, Current: 630 A)

1 (one) feeder with switch+fuse combination;

- Switch-fuse combination,
- Integrated capacitive voltage presence indicator system (VPIS),
- Operating mechanism (type MO19)
- Plug-in bushings
(Interface: B, Contact type: Sliding, Current: 400 A)
- Transformer Alarm Set (Annunciator)

SF₆ Gas Pressure Manometer

Main busbar, earthing bar and e-field equalizers)

Operating handle (anti-reflex)

HV Cable glands

Pad- locking facility

LV Panel

Optional Equipments

- SF₆ Gas Pressure Manometer (hermetic and double contact)
- Operating mechanism (typed MO19)
- Earth Fault Relay,
- Remote OPENING and CLOSING operation with cable (ROCO)
- HV FUSE integrated with thermal cut-out and pin striker (medium type)
- With more depth extended Cable Compartment *
(aiming to connect two T type connectors back to back on the same phase)
- SCADA compliance
- Surveillance window (for observing earthing switch position)
- Motor + Gear Box

For Extensible Type Compacts RMU's

- Extension Bushings,
- Extension bar and screened insulator
- Dummy/Ending plug



- Extended cable compartment depth is 77 mm more than standard cable compartment.
- Internal arc performance of extended cable compartment is proven by type test.

COMPACT TYPE RING MAIN UNIT [SFA-RM36.SSB]

Standard Equipments

2 (two) feeders with switch-disconnector;

- Switch-disconnector (*three-positioned, OPEN-CLOSED-EARTHED*)
- Integrated capacitive voltage presence indicator system (VPIS),
- Operating mechanism (*type M018*)
- Plug-in bushings (*Interface: C, Contact type: Bolted, Current: 630 A*)

1 (one) pc feeder with Vacuum Circuit Breaker;

- Vacuum Circuit Breaker,
- Disconnector with earthing switch,
- Over current relay,
- Current Transformer
- Integrated capacitive voltage presence indicator system (VPIS),
- Operating mechanism
- Plug-in bushings (*Interface: C, Contact type: Bolted, Current: 630 A*)
- Transformer Alarm Set (*in case of usage as a transformer protection*)

SF6 Gas Pressure Manometer

Main busbar, earthing bar and e-field equalizers)

Operating handle (*anti-reflex*)

HV Cable glands

Pad- locking facility

LV Panel

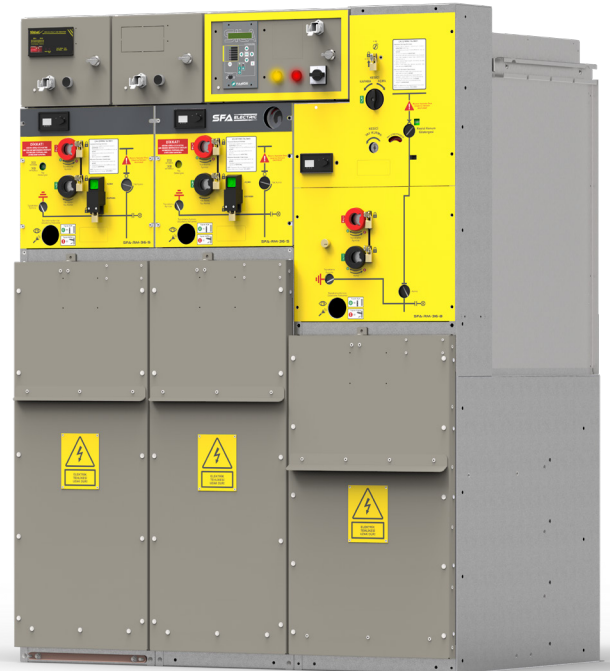

Optional Equipments

- SF6 Gas Pressure Manometer (*hermetic and double contact*)
- Operating mechanism for switch disconnectors (*typed M019*)
- Earth Fault Relay,
- Remote OPENING and CLOSING operation with cable (*ROCO*)
- With more depth extended Cable Compartment *
(*aiming to connect two T type connectors back to back on the same phase*)
- Self Powered Relay
- SCADA compliance
- Surveillance window (*for observing earthing switch position*)
- Motor + Gear Box (*for switch-disconnectors*)

For Extensible Type Compacts RMU's

- Extention Bushings,
- Extention bar and screened insulator
- Dummy/Ending plug



- Extended cable compartment depth is 77 mm more than standard cable compartment.
- Internal arc performance of extended cable compartment is proven by type test.

There is no need to use of Auxiliary Service Voltage to trip Circuit Breaker if Self Powered Relay is used.

36kV

SFA-RMSF6
GAS INSULATED RING MAIN UNITS**TYPES****CUBICLE WITH SWITCH-DISCONNECTOR [SFA-RM36.S]****Standard Equipments**

- Switch-disconnector (*three-positioned, OPEN-CLOSED-EARTHED*)
- Integrated capacitive voltage presence indicator system (VPIS),
- Operating mechanism (*type MO18*)
- Plug-in bushings (*Interface: C, Contact type: Bolted, Current: 630 A*)
- SF6 Gas Pressure Manometer
- Main busbar, earthing bar and e-field equalizers)
- Operating handle (*anti-reflex*)
- HV Cable glands
- Pad- locking facility
- LV Panel
- Extension Bushings,
- Extension bar and screened insulator
- Dummy/Ending plug

Optional Equipments

- SF6 Gas Pressure Manometer (*hermetic and double contact*)
- Operating mechanism (*typed MO19*)
- Earth Fault Relay,
- Remote OPENING and CLOSING operation with cable (ROCO)
- With more depth extended Cable Compartment * (*aiming to connect two T type connectors back to back on the same phase*)
- SCADA compliance
- Surveillance window (*for observing earthing switch position*)
- Motor + Gear Box
- Ampermeter
- AC/DC Battery Rectifier Set
- Lateral incoming with outer cone bushing

CUBICLE WITH SWITCH-DISCONNECTOR **SFA-RM36.S**S
03

- *Extended cable compartment depth is 77 mm more than standard cable compartment.*
- *Internal arc performance of extended cable compartment is proven by type test.*

CUBICLE WITH SWITCH-FUSE COMBINATION [SFA-RM36.F]

Standard Equipments

- Switch-fuse combination,
- Integrated capacitive voltage presence indicator system (VPIS),
- Operating mechanism (type M019)
- Plug-in bushings
(Interface: B, Contact type: Sliding, Current: 400 A)
- Transformer Alarm Set (Annunciator)
- SF6 Gas Pressure Manometer
- Main busbar, earthing bar and e-field equalizers)
- Operating handle (anti-reflex)
- HV Cable glands
- Pad- locking facility
- LV Panel
- HV Fuse enclosure (epoxy)
- Earthing switch (1 kA)
- Extension Bushings,
- Extension bar and screened insulator
- Dummy/Ending plug

Optional Equipments

- SF6 Gas Pressure Manometer (hermetic and double contact)
- Remote OPENING and CLOSING operation with cable (ROCO)
- SCADA compliance
- Surveillance window (for observing earthing switch position)
- Motor + Gear Box
- AC/DC Battery Rectifier Set
- Lateral incoming with outer cone bushing
- HV FUSE integrated with thermal cut-out and pin striker
(medium type)



Outer Cone Plug-in Bushing for lateral incoming
 (EN 50181, Interface: C, bolted, 630 A)

CUBICLE WITH SWITCH-FUSE COMBINATION SFA-RM36.F

F
 04

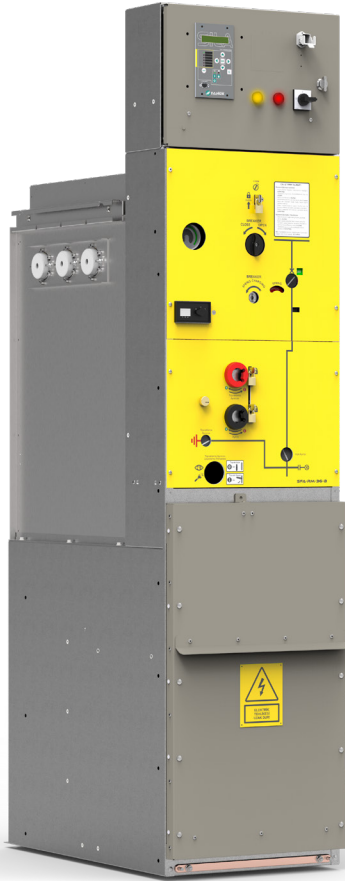

Standard Equipments

- Vacuum Circuit Breaker,
- Disconnecter wth earthing switch,
- Over current relay,
- Current Transformer,
- Integrated capacitive voltage presence indicator system (VPIS),
- Operating mechanism
- Plug-in bushings (*Interface: C, Contact type: Bolted, Current: 630 A*)
- Transformer Alarm Set (*in case of usage as a transformer protection*)
- SF₆ Gas Pressure Manometer
- Main busbar, earthing bar and e-field equalizers
- Operating handle (*anti-reflex*)
- HV Cable glands
- Pad- locking facility
- LV Panel
- Extention Bushings,
- Extention bar and screened insulator
- Dummy/Ending plug

Optional Equipments

- SF₆ Gas Pressure Manometer (*hermetic and double contact*)
- Earth Fault Relay,
- Remote OPENING and CLOSING operation with cable (ROCO)
- With more depth extended Cable Compartment *
(*aiming to connect two T type connectors back to back on the same phase*)
- Self Powered Relay
- SCADA compliance

B CUBICLE WITH VACUUM CIRCUIT BREAKER **SFA-RM36.B**



Outer Cone Plug-in Bushing for lateral incoming
(EN 50181, Interface: C, bolted, 630 A)



- *Extended cable compartment depth is 77 mm more than standard cable compartment.*
- *Internal arc performance of extended cable compartment is proven by type test.*

CUBICLE WITH BUS BAR COUPLING [SFA-RM36.C]

Standard Equipments

- Switch-disconnector (*three-positioned, OPEN-CLOSED-EARTHED*)
- Integrated capacitive voltage presence indicator system (*VPIS*),
- Operating mechanism (*type M018*)
- SF6 Gas Pressure Manometer
- Main busbar, earthing bar and e-field equalizers
- Operating handle (*anti-reflex*)
- Pad- locking facility
- LV Panel
- Extention Bushings,
- Extention bar and screened insulator

Optional Equipments

- SF6 Gas Pressure Manometer (*hermetic and double contact*)
- Operating mechanism (*typed M019*)
- Remote OPENING and CLOSING operation with cable (*ROCO*)
- SCADA compliance
- Surveillance window (*for observing earthing switch position*)
- Motor + Gear Box
- AC/DC Battery Rectifier Set

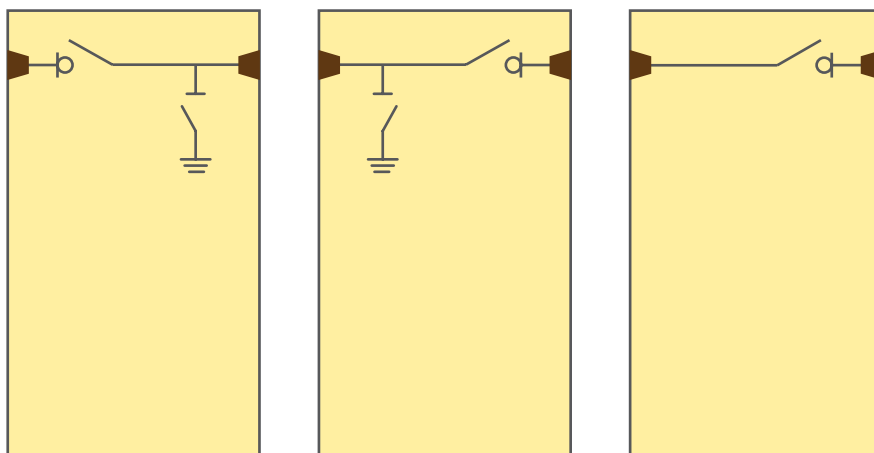

CUBICLE WITH BUS BAR COUPLING **SFA-RM36.C**



06

36kV

SFA-RMSF6
GAS INSULATED RING MAIN UNITS**TYPES****METERING (CT+VT) GROUP WITH SWITCH-DISCONNECTOR****[SFA-RM36.M[S]**

SFA - RM36.M (S)

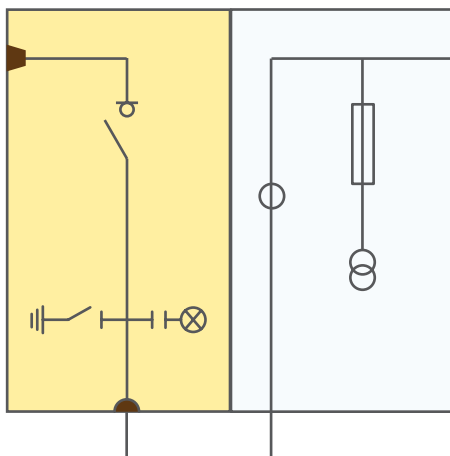

SFA - RM36.M

**Standard Equipments****SF6 Gas Insulated Switch-Disconnecter Cubicle (SFA-RM36.S)**

- Switch-disconnector
(*three-positioned, OPEN-CLOSED-EARTHED*)
- Integrated capacitive voltage presence indicator system (VPIS),
- Operating mechanism (*type M018*)
- Plug-in bushings
(*Interface: C, Contact type: Bolted, Current: 630 A*)
- SF6 Gas Pressure Manometer
- Main busbar, earthing bar and e-field equalizers
- Operating handle (*anti-reflex*)
- HV Cable glands
- Pad- locking facility
- LV Panel
- Extension Bushings,
- Extension bar and screened insulator

Air Insulated Metering (CT+VT) Cubicle (SFA-RM36.M)

- Busbar,
- Current Transformers,
- Voltage Transformers,
- Voltmeter and Voltmeter Selector Switch
- Active/Reactive Power Meter
- HV Fuses for Voltage Transformers

HV Cable Connection Between Cubicles*(equipped with cable terminations)***Optional Equipments**

- SF6 Gas Pressure Manometer (*hermetic and double contact*)
- Operating mechanism (*typed M019*)
- Remote OPENING and CLOSING operation with cable (ROCO)
- SCADA compliance
- Surveillance window (*for observing earthing switch position*)
- Motor + Gear Box for switch-disconnector
- AC/DC Battery Rectifier Set
- Power analyser,
- Power Quality Recorder
- Lateral incoming with outer cone bushing for switch-disconnector cubicle

METERING (CT+VT) GROUP WITH VACUUM CIRCUIT BREAKER [SFA-RM36.M[B]

Standard Equipments

SF6 Gas Insulated Vacuum Circuit Breaker Cubicle (SFA-RM36.B)

- Vacuum Circuit Breaker,
- Disconnecter with earthing switch,
- Over current relay,
- Current Transformer,
- Integrated capacitive voltage presence indicator system (VPIS),
- Operating mechanism
- Plug-in bushings (Interface: C, Contact type: Bolted, Current: 630 A)
- SF6 Gas Pressure Manometer
- Main busbar, earthing bar and e-field equalizers
- Operating handle (anti-reflex)
- HV Cable glands
- Pad- locking facility
- LV Panel
- Extension Bushings,
- Extension bar and screened insulator

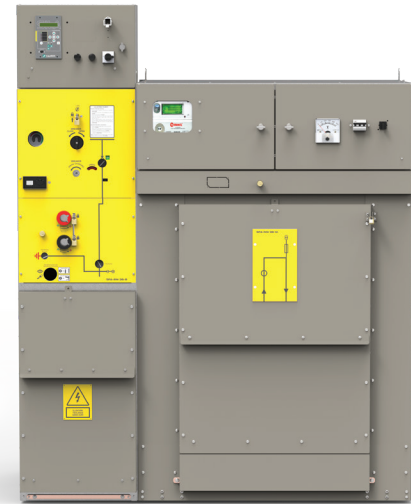

SFA - RM36.M (B)

Air Insulated Metering (CT+VT) Cubicle (SFA-RM36.M)

- Busbar,
- Current Transformers,
- Voltage Transformers,
- Voltmeter and Voltmeter Selector Switch
- Active/Reactive Power Meter
- HV Fuses for Voltage Transformers



SFA - RM36.M

HV Cable Connection Between Cubicles

(equipped with cable terminations)

Optional Equipments

- SF6 Gas Pressure Manometer (hermetic and double contact)
- Remote OPENING and CLOSING operation with cable (ROCO)
- SCADA compliance
- Surveillance window (for observing earthing switch position)
- AC/DC Battery Rectifier Set
- Power analyser,
- Power Quality Recorder
- Lateral incoming with outer cone bushing for circuit breaker cubicle

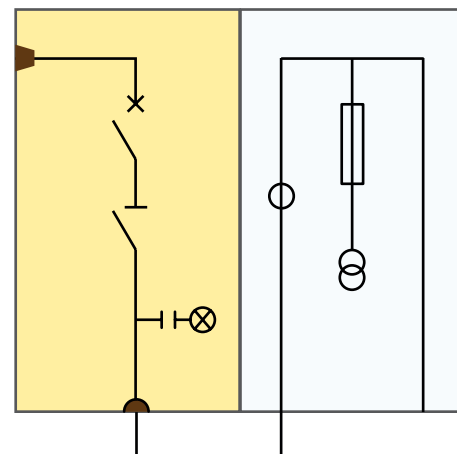

METERING (CT+VT) GROUP WITH VACUUM CIRCUIT BREAKER SFA-RM36.M[B]

36kV

SFA-RMSF₆
GAS INSULATED RING MAIN UNITS**TYPES****METERING (CT+VT) GROUP WITH SWITCH-FUSE COMBINATION****[SFA-RM36.M[F]**

SFA-RM36.M (F)

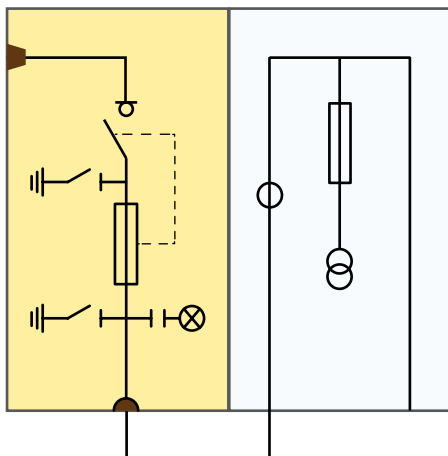

SFA - RM36.M

**Standard Equipments****SF₆ Gas Insulated Switch-Fuse Combination Cubicle (SFA-RM36.F)**

- Switch-fuse combination,
- Integrated capacitive voltage presence indicator system (VPIS),
- Operating mechanism (*type M019*)
- Plug-in bushings
(*Interface: B, Contact type: Sliding, Current: 400 A*)
- Transformer Alarm Set (*Annunciator*)
- SF₆ Gas Pressure Manometer
- Main busbar, earthing bar and e-field equalizers
- Operating handle (anti-reflex)
- HV Cable glands
- Pad- locking facility
- LV Panel
- HV Fuse enclosure (*epoxy*)
- Earthing switch (*1 kA*)
- Extension Bushings,
- Extension bar and screened insulator

Air Insulated Metering (CT+VT) Cubicle (SFA-RM36.M)

- Busbar,
- Current Transformers,
- Voltage Transformers,
- Voltmeter and Voltmeter Selector Switch
- Active/Reactive Power Meter
- HV Fuses for Voltage Transformers

HV Cable Connection Between Cubicles*(equipped with cable terminations)***Optional Equipments**

- SF₆ Gas Pressure Manometer (*hermetic and double contact*)
- Remote OPENING and CLOSING operation with cable (*ROCO*)
- SCADA compliance
- Surveillance window (*for observing earthing switch position*)
- Motor + Gear Box
- AC/DC Battery Rectifier Set
- Lateral incoming with outer cone bushing
- HV FUSE integrated with thermal cut-out and pin striker (*medium type*)
- Power analyser,
- Power Quality Recorder

VOLTAGE METERING GROUP WITH SWITCH-DISCONNECTOR
[SFA-RM36.V[S]

Standard Equipments

SF6 Gas Insulated Switch-Disconnecter Cubicle (SFA-RM36.S)

- Switch-disconnector
(three-positioned, OPEN-CLOSED-EARTHED)
- Integrated capacitive voltage presence indicator system (VPIS),
- Operating mechanism *(type M018)*
- Plug-in bushings *(Interface: C, Contact type: Bolted, Current: 630 A)*
- SF6 Gas Pressure Manometer
- Main busbar, earthing bar and e-field equalizers
- Operating handle *(anti-reflex)*
- HV Cable glands
- Pad- locking facility
- LV Panel
- Extention Bushings,
- Extention bar and screened insulator



SFA-RM36.V (S)

Air Insulated Metering (VT) Cubicle (SFA - RM36.V)

- Busbar,
- Voltage Transformers,
- Voltmeter and Voltmeter Selector Switch
- HV Fuses for Voltage Transformers

HV Cable Connection Between Cubicles
(equipped with cable terminations)

Optional Equipments

- SF6 Gas Pressure Manometer *(hermetic and double contact)*
- Operating mechanism *(typed M019)*
- Remote OPENING and CLOSING operation with cable *(ROCO)*
- SCADA compliance
- Surveillance window *(for observing earthing switch position)*
- Motor + Gear Box for switch-disconnector
- Power analyser,
- Power Quality Recorder
- AC/DC Battery Rectifier Set
- Lateral incoming with outer cone bushing for switch-disconnector cubicle

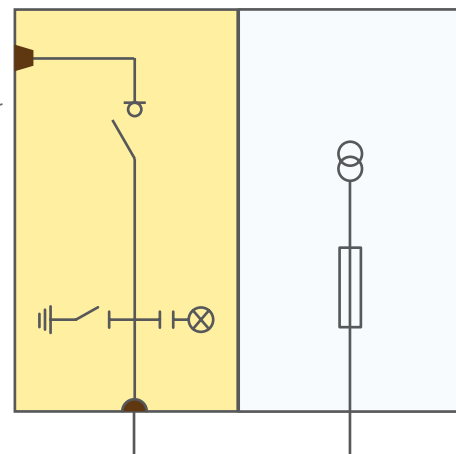

V[S] SF6 GAS INSULATED SWITCH-DISCONNECTOR CUBICLE SFA-RM36.V[S]



36kV

SFA-RM

SF6
GAS INSULATED RING MAIN UNITS

TYPES

CABLE RISING CUBICLE [SFA-RM36.CR]



Standard Equipments

- Integrated capacitive voltage presence indicator system (VPIS),
- HV Cable fixing gland

Optional Equipments

- HV Connection Cable
(both side equipped with Cable Terminations)



Outer cone plug-in bushing to be connected XLPE cable should be met the EN 50181 and having interface "C".



CABLE RISING CUBICLE **SFA-RM36.CR**

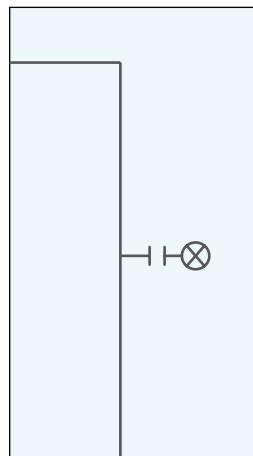

LEFT side connection

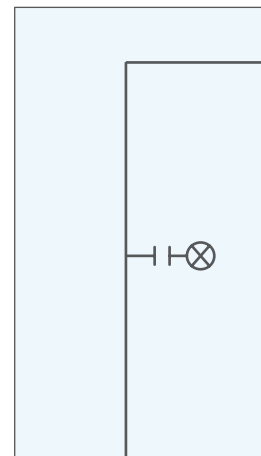

RIGHT side connection

CUBICLE WITH VACUUM CIRCUIT BREAKER EQUIPPED WITH CT+VT [SFA-RM36.B[CV]

Standard Equipments

- Vacuum Circuit Breaker,
- Disconnecter with earthing switch,
- Over current relay,
- Current Transformers,
- Voltage Transformers,
- Integrated capacitive voltage presence indicator system (VPIS),
- Operating mechanism
- Plug-in bushings (*Interface: C, Contact type: Bolted, Current: 630 A*)
- Transformer Alarm Set (*in case of usage as a transformer protection*)
- SF6 Gas Pressure Manometer
- Main busbar, earthing bar and e-field equalizers
- Operating handle (*anti-reflex*)
- HV Cable glands
- Pad- locking facility
- LV Panel
- Extention Bushings,
- Extention bar and screened insulator
- Dummy/Ending plug



Optional Equipments

- SF6 Gas Pressure Manometer (*hermetic and double contact*)
- Earth Fault Relay,
- Remote OPENING and CLOSING operation with cable (ROCO)
- With more depth extended Cable Compartment (*aiming to connect two T type connectors back to back on the same phase*)
- Self Powered Relay
- SCADA compliance

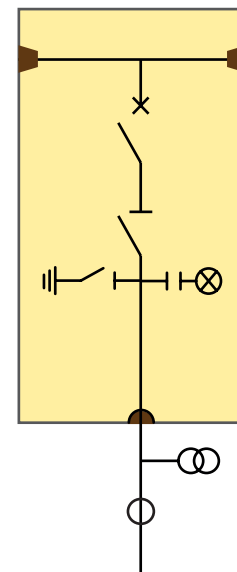

MV terminal bushings of Voltage Transformer should be met EN 50181, plug-in typed and having interface "C".

CUBICLE WITH VACUUM CIRCUIT BREAKER EQUIPPED WITH CT+VT **SFA-RM36.B[CV]**

B[CV]

12

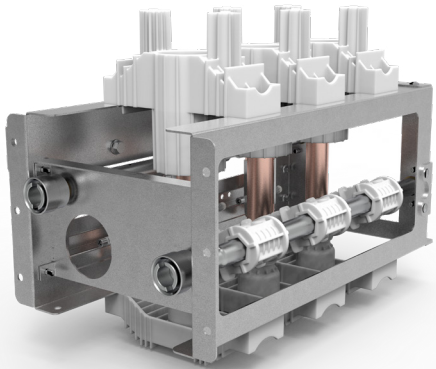

SWITCH-DISCONNECTOR (with earthing switch)

- Applied standart: IEC 62271-103
- Three-phase, three positioned (*OPEN-CLOSE-EARTHED*)
- Load current is quenching in the SF6
- Electrical endurance class: E3,
- Mechanical endurance class: M1

OPERATING MECHANISM OF THE SWITCH-DISCONNECTOR

For earthing switch;

- Electrical endurance class: E2,
- Mechanical endurance class: M1

Operating Mechanism;

- Stored energy operation
- Standart mechanism: Type M018
- Optional mechanism: Type M019
- Independent of the operator operation,
- Comply to motor

M018 Type Mechanism

- Opening and Closing operation takes place at one stage. The position of the switch (*closing, opening and earthing operation*) is performed manually by the Operating Handle. For motorized types, mentioned operation is performed via geared motor.

M019 Type Mechanism

- Energy storage is performed by the operator using by Operating Handle or via geared motor (*for motorized mechanism*)

Relasing of the energy is performed;

- By operator with using push button (*mechanically*)
- By shunt coils (*electrically*)
- By striker pin on the switch-fuse combination (*mechanically*)

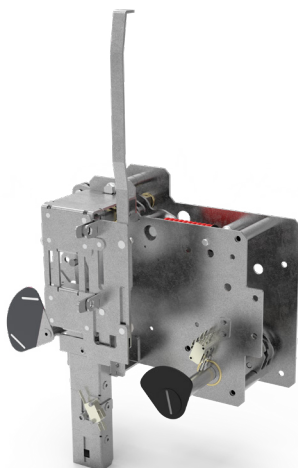

M 018

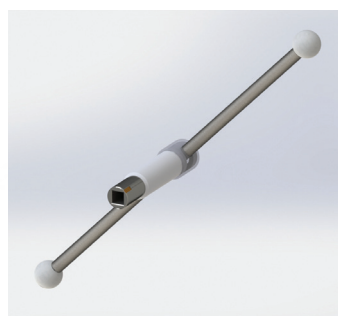

Operating Handle

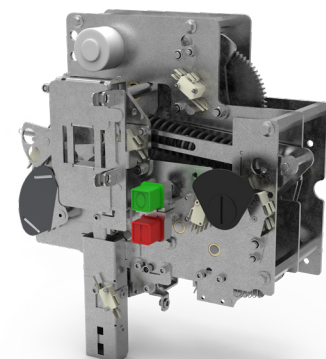

M 019

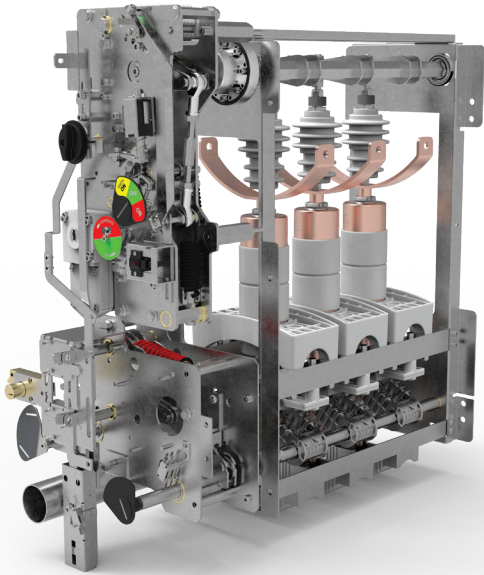

VACUUM CIRCUIT BREAKER+DISCONNECTOR WITH EARTHING SWITCH UNIT

Vacuum Circuit Breaker;

- Applied standard: IEC 62271-100
- Electrical Endurance Class: E2
(for which are used in the cable network)
- Mechanical Endurance Class: M1 (2000 times)

Disconnecter;

- Applied standart: IEC 62271-102
- Three-phase, three positoned (OPEN-CLOSED-EARTHED)
- Mechanical Endurance Class: M1 (1000 times)

Earthing switch;

- Applied standart: IEC 62271-102
- Electrical Endurance Class: E2 (5 times making on short circuit)
- Mechanical Endurance Class: M1 (1000 times)

OPERATING MECHANISM OF THE VACUUM CIRCUIT BREAKER

- Operating mechanism is based on Stored Energy within a spring. Storing of energy is provided with either geared MOTOR (*electrically*) or operating handle (*manualy*). Relasing of energy is provided with either push button on the front panel (*manualy*) or shunt coil (*electricaly*)
- Opening spring is charged during the closing operation. So, it always stays for tripping.
- Suitable for rapid re-closing.
- Suitable for Self Powered Relay application

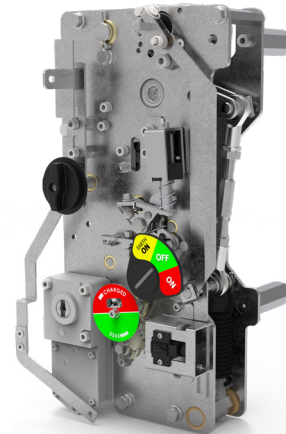

AUXILIARY SERVICE VOLTAGES

	VOLTAGE*
Motor	220 VAC; 220 VDC; 110 VDC; 24 VDC; 48 VDC
Coil	24 VDC; 48 VDC, 110 VDC

*Get in contact with SFA ELECTRIC if different service voltage is requested.

36kV SFA-RM SF6 GAS INSULATED RING MAIN UNITS CONTROL PANEL

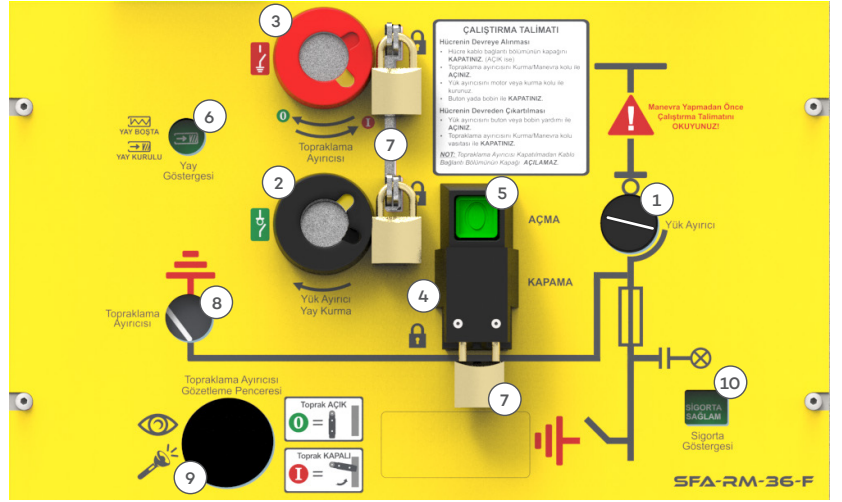
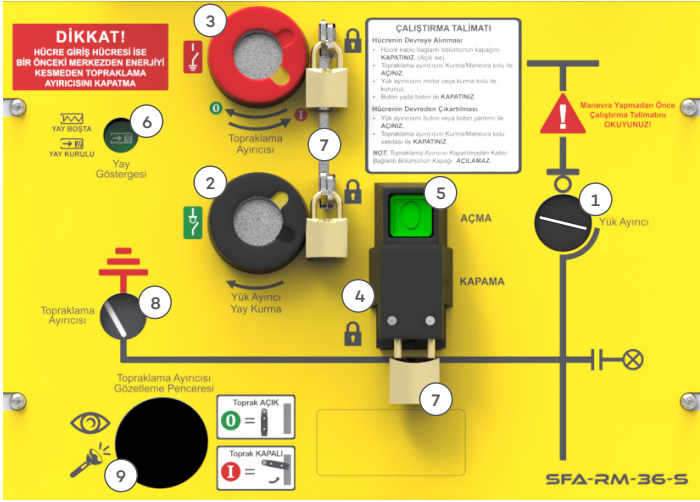

FOR CUBICLE WITH SWITCH-DISCONNECTOR (for MO19 typed mechanism)

1. Position indicator for switch-disconnector
2. Operating Handle Slot for switch-disconnector
3. Operating Handle Slot for earthing switch
4. Push Button for closing operation of switch-disconnector (mechanically)
5. Push Button for opening operation of switch-disconnector (mechanically)
6. "Spring Charged" or "Spring Discharged" indicator for switch-disconnector
7. Pad-locking
8. Position indicator for earthing switch
9. Surveillance window (for earthing switch contact position)

FOR CUBICLE WITH SWITCH FUSE COMBINATION (for MO19 typed mechanism)

1. Position indicator for switch-disconnector
2. Operating Handle Slot for switch-disconnector
3. Operating Handle Slot for earthing switch
4. Push Button for closing operation of switch-disconnector (mechanically)
5. Push Button for opening operation of switch-disconnector (mechanically)
6. "Spring Charged" or "Spring Discharged" indicator for switch-disconnector
7. Padlocking
8. Position indicator for earthing switch
9. Surveillance window (for earthing switch contact position)
10. HV Fuse indicator

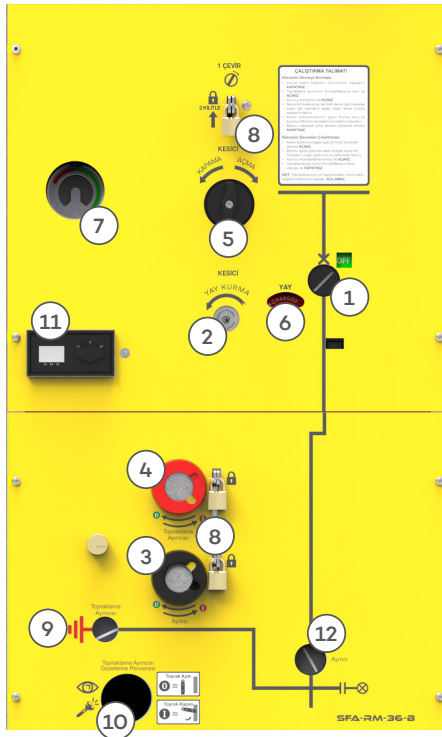

FOR CUBICLE WITH VACUUM CIRCUIT BREAKER

1. Position indicator for Circuit Breaker
2. Operating Handle Shaft for charging spring
3. Operating Handle Shaft for disconnecter
4. Operating Handle Shaft for earthing switch
5. Thump knot for OPENING and CLOSING
6. "Spring Charged" or "Spring Discharged" indicator for switch disconnecter
7. SF6 Gas Manometer
8. Padlocking
9. Position indicator for earthing switch
10. Surveillance window (for earthing switch contact position)
11. Voltage Presence Indicator
12. Position indicator for disconnecter

Cable Connection of the SFA-RM.36 is done in the Cable Connection Compartment which is located at the front of the cubicle by using Separable Cable Connectors.

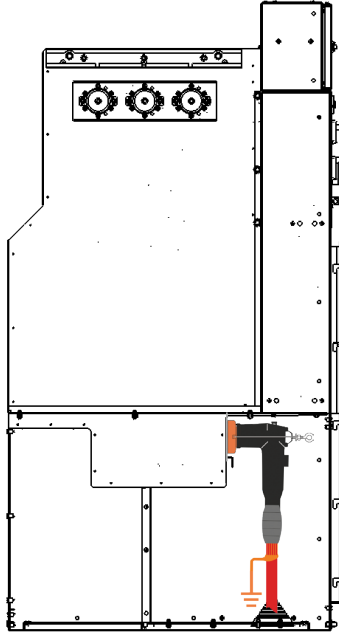

Separable Connector type : "L" type

Contact type : Sliding

Rated Current : 400 A

Interface : B

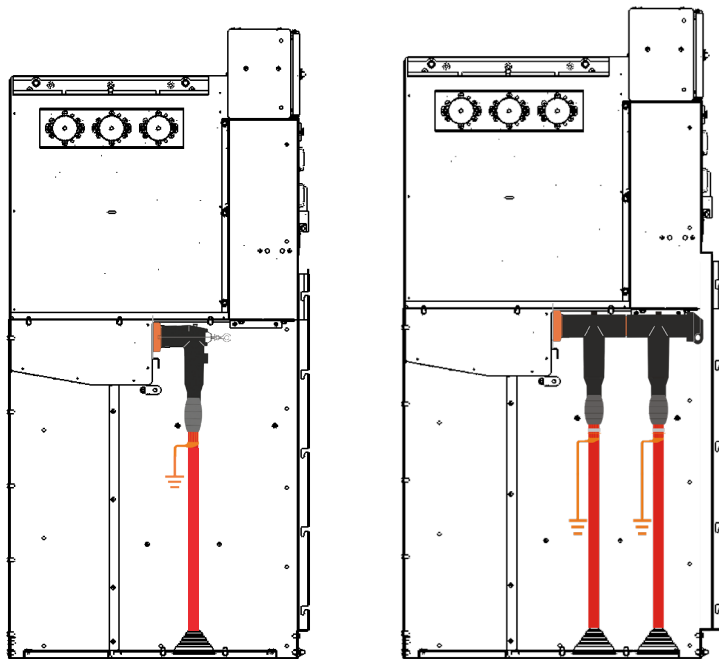

Separable Connector type : "T" type

Contact type : Bolted

Rated Current : 630 A

Interface : C



WARNING!

1. Separable Connectors to be used should have type test reports/certificates according to the related standards.
2. The Installation Instructions of the manufacturer must be followed.
3. Metal screen of the HV cable should be connected to the earthing bar of the cubicle.

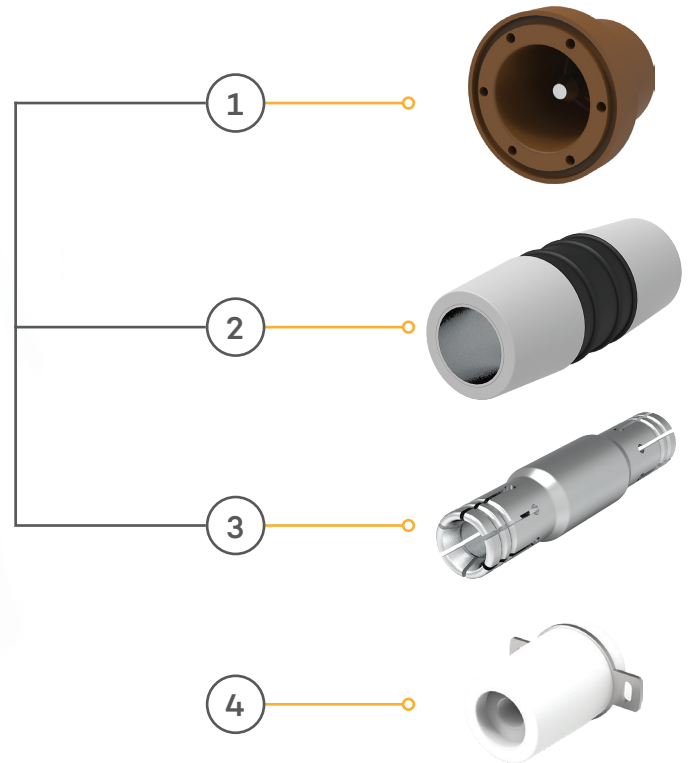

Extension Kit

1	Extension Bushing
2	Screened insulator
3	Extension Busbar
4	Dummy/Ending plug

Required functional unit can be connected side by side by using Extension Kit. Unused side should be covered by dummy/ending plug.

Extension Kit equipment;

- Type tested,
- Pre fabricated
- Withstand to rated voltage and rated short time withstand current of the cubicles.

36kV
SFA-RM
 SF6
 GAS INSULATED RING MAIN UNITS
HV FUSE

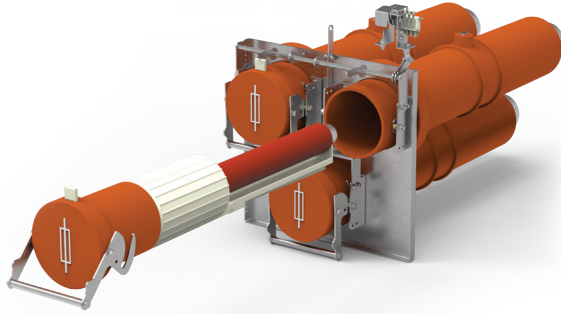

HV Fuses to be used in SFA-RM36 should be integrated thermal cut-out type and with striker (medium).



VOLTAGE	DIMENSIONS (mm)	
	A	D
17.5kV	33	367
24kV	33	442
36kV	33	537

Rated Voltage (kV)	36 kV						
Rated Power (kVA)	250	400	630	800	1000	1250	1600
% Uk	4,5			6			
İnterteknik (Tip: ACT)	16A	16A	20A	25A	31,5A	40A	50A
Güral	16A	16A	20A	25A	30A	40A	50A



In case of using except 36 kV voltage level, please contact with SFA ELECTRIC to determine correct HV Fuse.

ACCESSIBILITY AND COMPLIANCE WITH STANDARDS

	STANDARDS	CLASSIFICATION	
		Partition	PM
SFA-RM 36	IEC 62271-200	Loss of Service Continuity	LSC 2
		Internal arc (for compact type)	A (FL) 16 kA-1 s
		Internal arc (for modular type)	A (FLR) 16 kA-1 s
SWITCH-DISCONNECTOR	IEC 62271-103	General purpose, M1, E3	
SWITCH-FUSE COMBINATION	IEC 62271-105		
CIRCUIT BREAKER	IEC 62271-100	M1, E2 (for cable network)	
DISCONNECTOR	IEC 62271-102	M1, E0	
EARTHING SWITCH	IEC 62271-102	M1, E2	
VOLTAGE DETECTION SYSTEM	IEC 61243-5	Voltage Presence Indicating System (VPIS)	
PLUG-IN BUSHINGS	IEC 50181	Outer cone plug-in bushing	

	IP CLASS	ACCESSIBILITY	INTERLOCKINGS
SWITCHING COMPARTMENT	IP 67	NON-ACCESSIBLE	-
HV CABLE CONNECTION COMPARTMENT	IP2X	ACCESSIBLE	Unless the earthing switch is earthed, the cover of the compartment can not be opened.
HV FUSE COMPARTMENT	IP3X	ACCESSIBLE	Unless the up and down-stream earthing switches are earthed, the cover of the compartment can not be opened.
OPERATING MECHANISM COMPARTMENT	IP2X	ACCESSIBLE	Accessible with tool.
LV PANEL COMPARTMENT	IP3X	ACCESSIBLE	-

01. COMPACT RING MAIN UNIT [SFA-RM36.SSF]

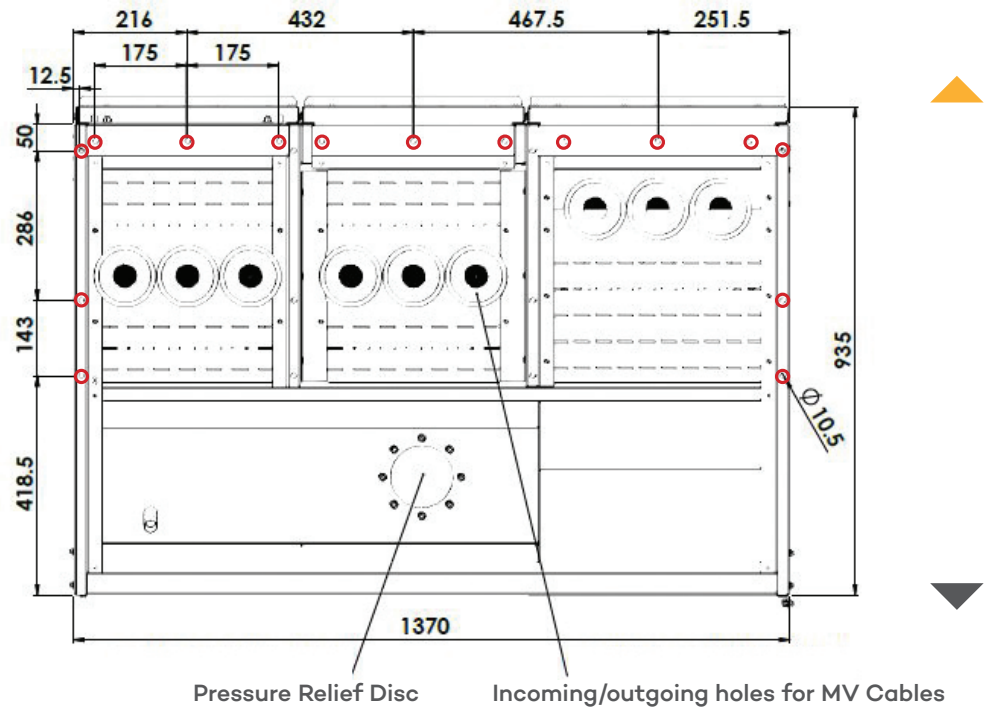
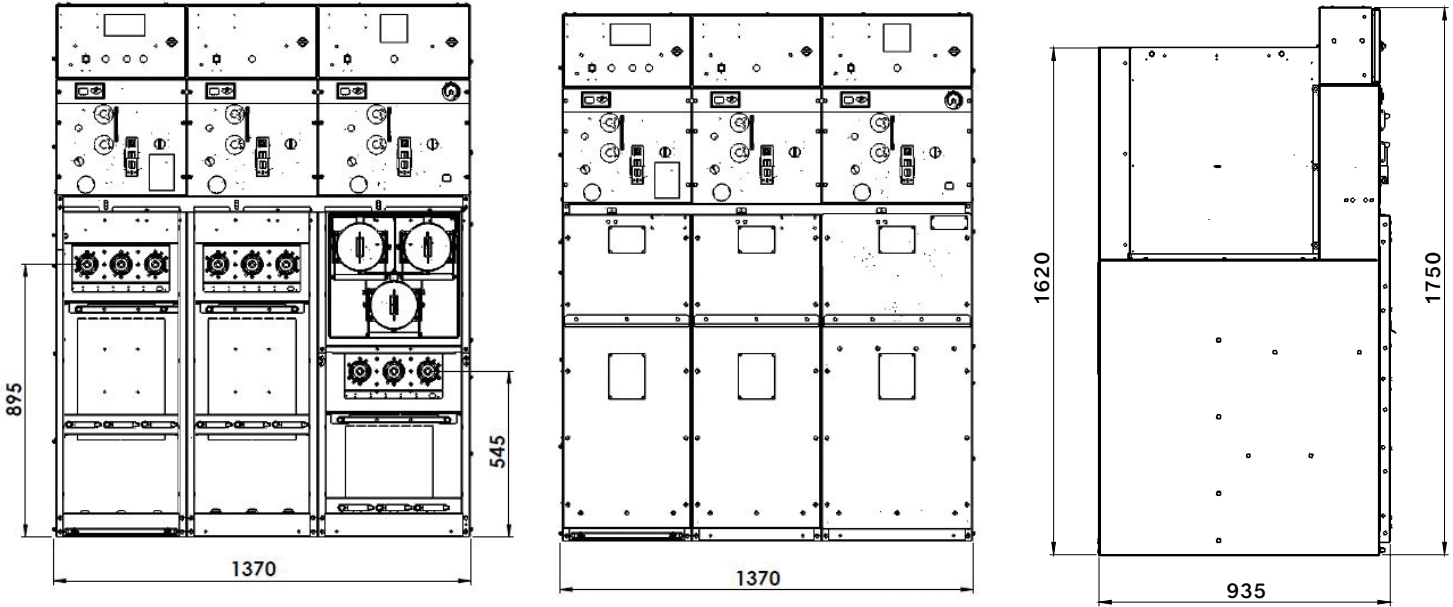

Single Line

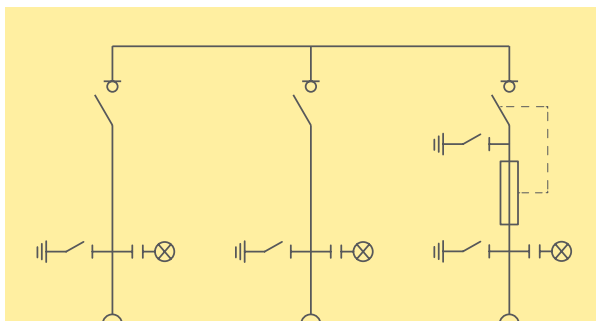

- Fixing points
- ▲ Front
- ▼ Rear



- Extended cable compartment depth is 77 mm more than standard cable compartment.
- Internal arc performance of extended cable compartment is proven by type test.

DIMENSIONS, SINGLE LINE DIAGRAMS AND VIEWS

02. COMPACT RING MAIN UNIT [SFA-RM36.SSB]

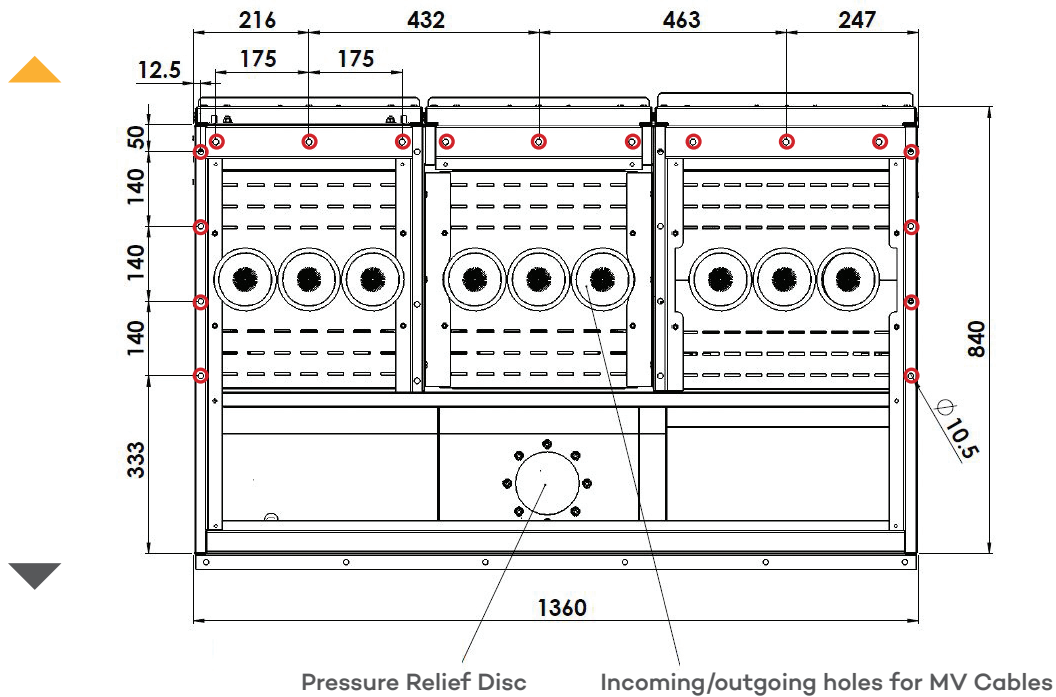
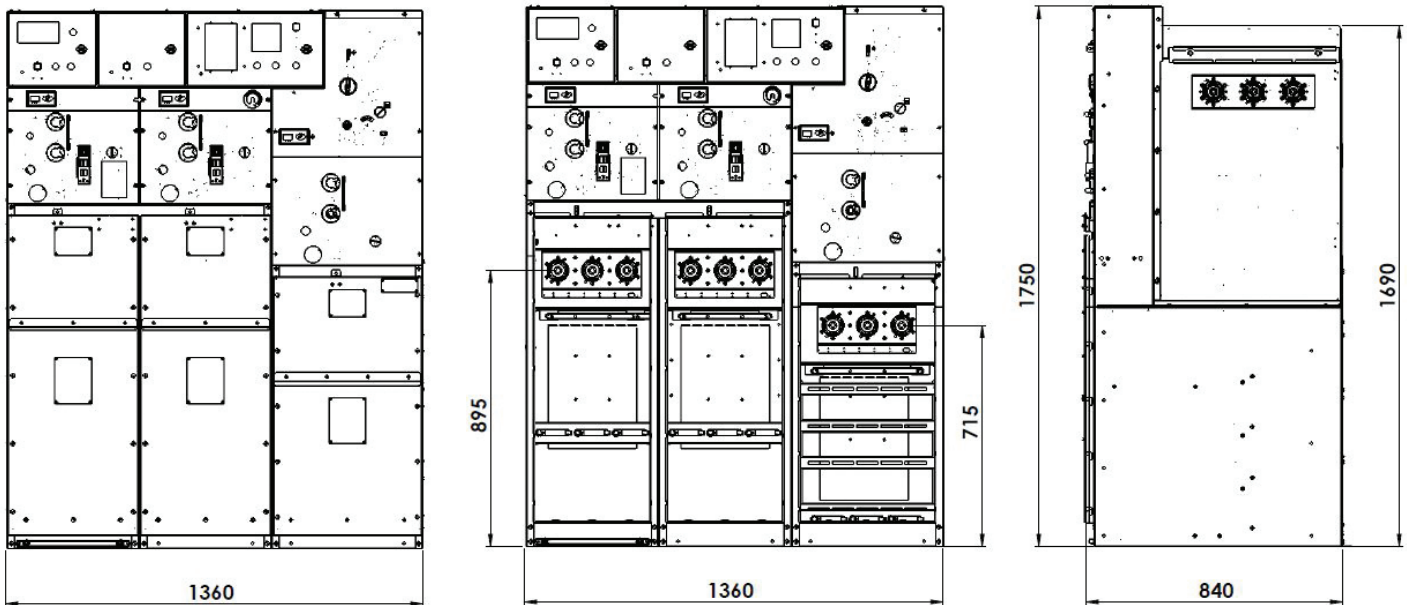

Single Line

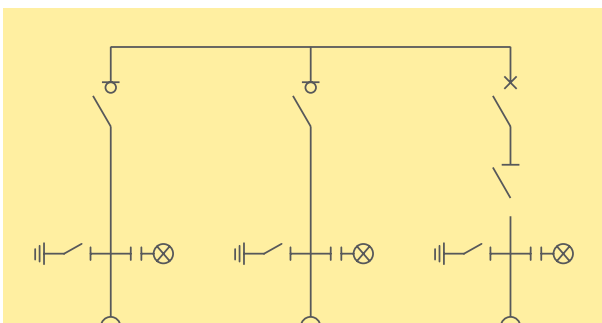

- Fixing points
- ▲ Front
- ▼ Rear



- Extended cable compartment depth is 77 mm more than standard cable compartment.
- Internal arc performance of extended cable compartment is proven by type test.

COMPACT TYPE RING MAIN UNIT SFA-RM36.SSB

SSB

03. CUBICLE WITH SWITCH-DISCONNECTOR [SFA-RM36.S]

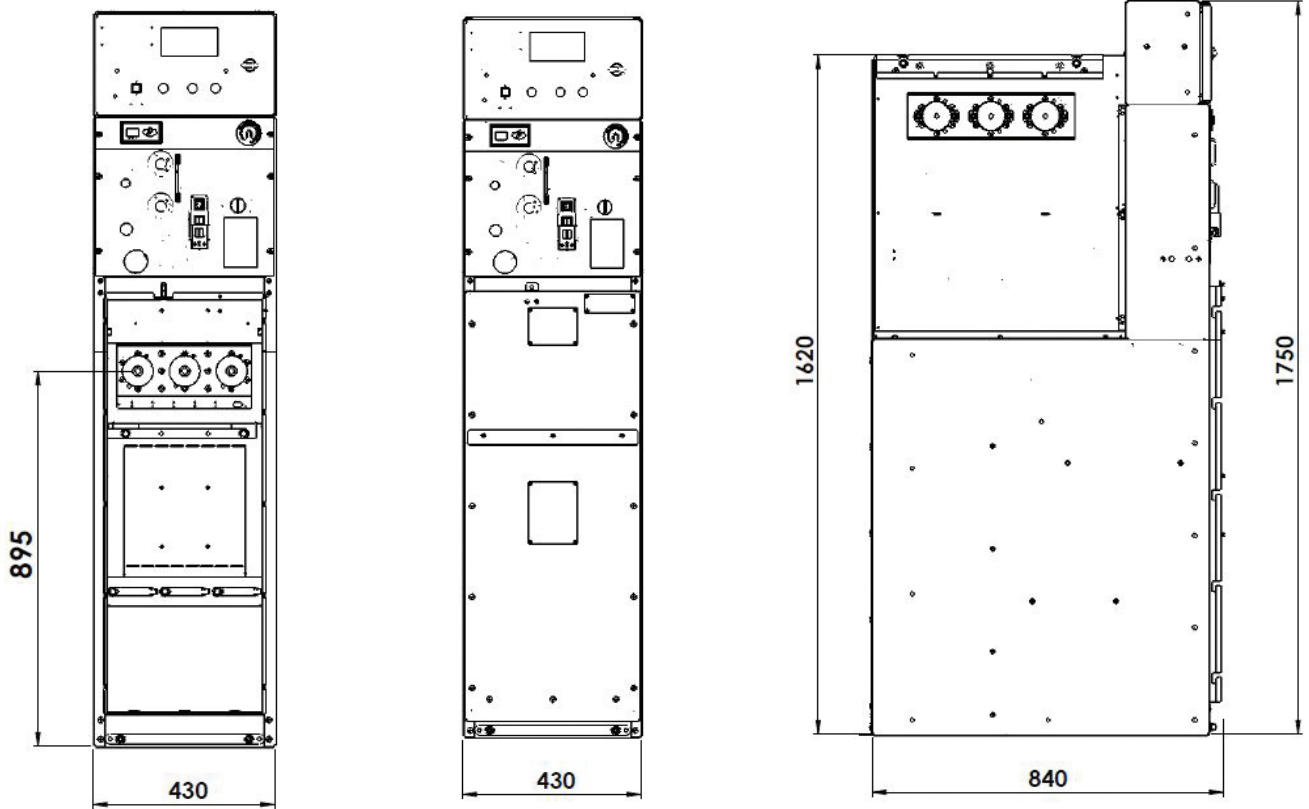

S CUBICLE WITH SWITCH-DISCONNECTOR SFA-RM36.S



- Extended cable compartment depth is 77 mm more than standard cable compartment.
- Internal arc performance of extended cable compartment is proven by type test.

Single Line

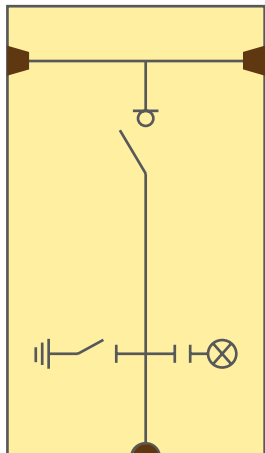

Incoming/outgoing holes for MV Cables

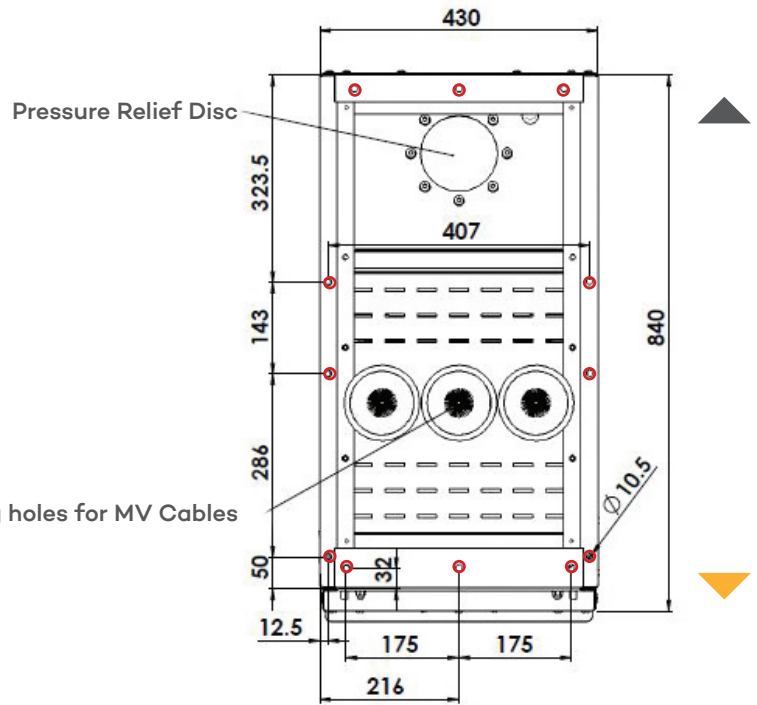

○ Fixing points

▲ Front

▼ Rear

DIMENSIONS, SINGLE LINE DIAGRAMS AND VIEWS

**04. CUBICLE WITH SWITCH-FUSE COMBINATION FOR TRANSFORMER
[SFA-RM36.F]**

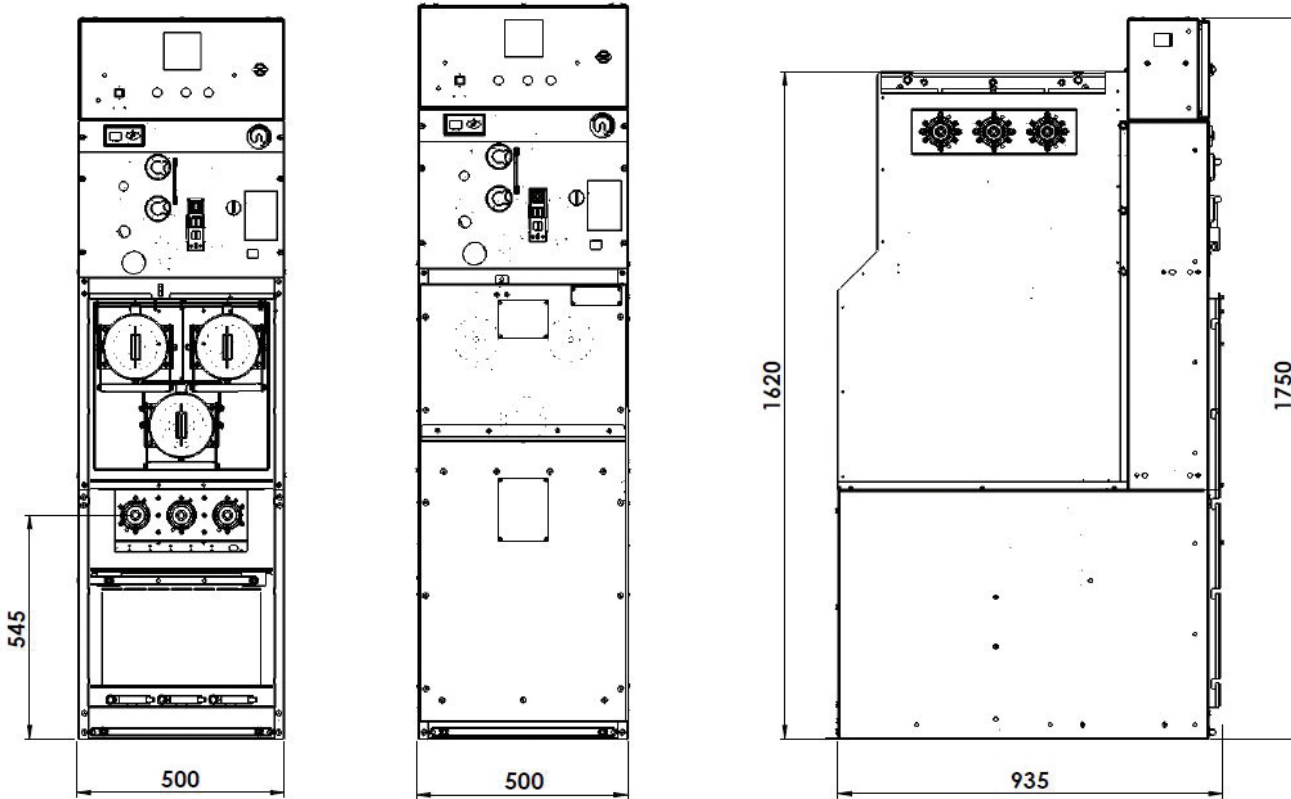

- Extended cable compartment depth is 77 mm more than standard cable compartment.
- Internal arc performance of extended cable compartment is proven by type test.

Single Line

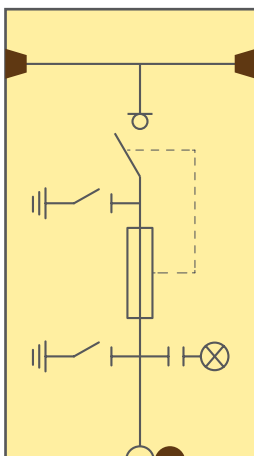

Pressure Relief Disc

Incoming/outgoing holes for MV Cables

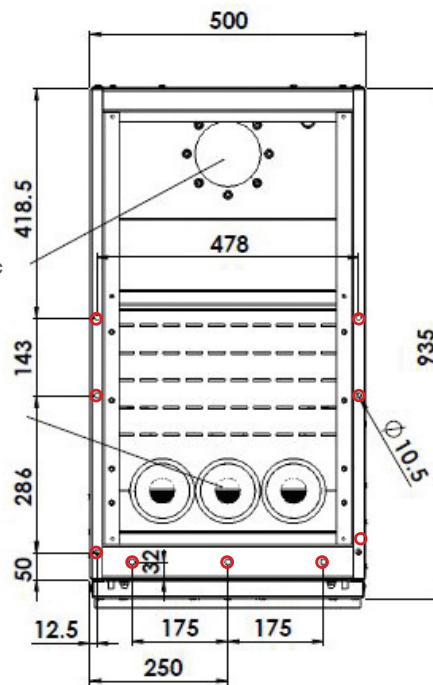

○ Fixing points

▲ Front

▼ Rear

CUBICLE WITH SWITCH-FUSE COMBINATION SFA-RM36.F

F
04

05. CUBICLE WITH VACUUM CIRCUIT BREAKER [SFA-RM36.B]

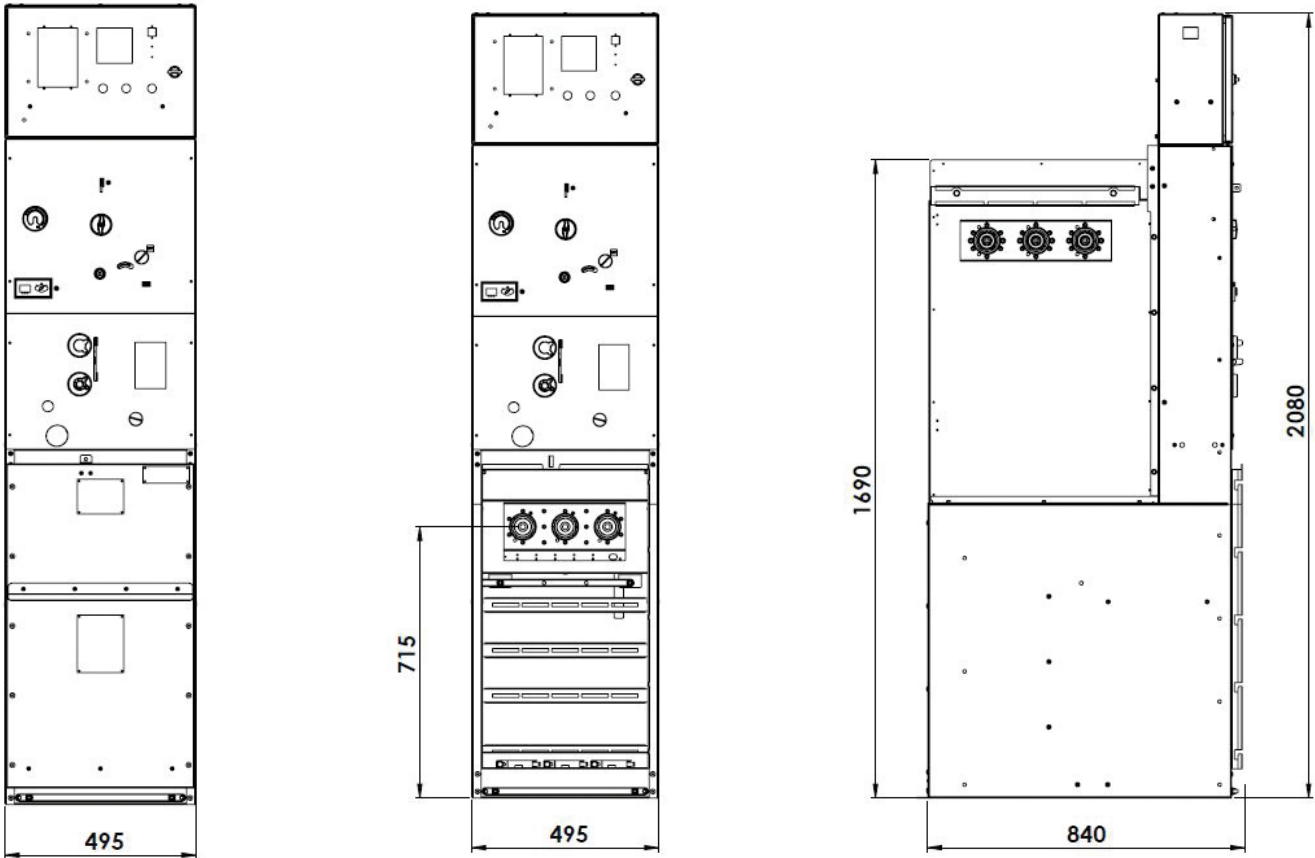

B CUBICLE WITH VACUUM CIRCUIT BREAKER **SFA-RM36.B**



- Extended cable compartment depth is 77 mm more than standard cable compartment.
- Internal arc performance of extended cable compartment is proven by type test.

Single Line

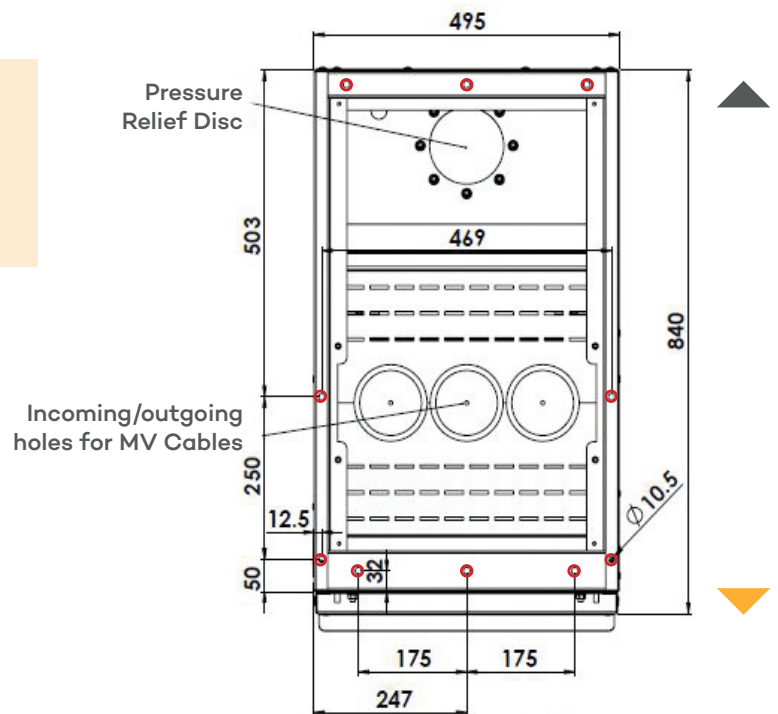
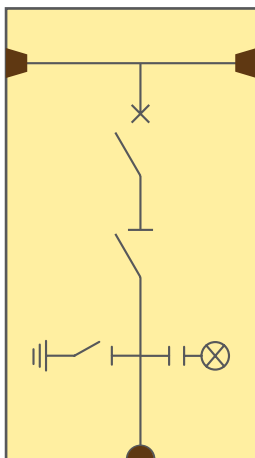

○ Fixing points

▲ Front

▼ Rear

DIMENSIONS, SINGLE LINE DIAGRAMS AND VIEWS
06. CUBICLE WITH BUS-BAR COUPLING [SFA-RM36.C]

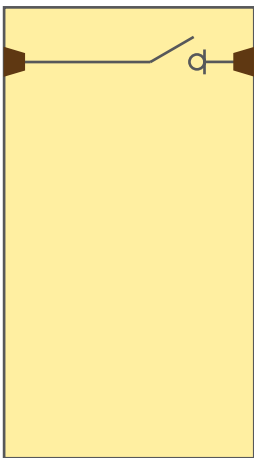
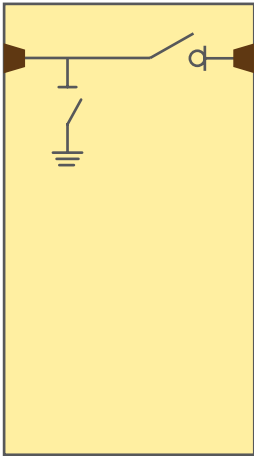
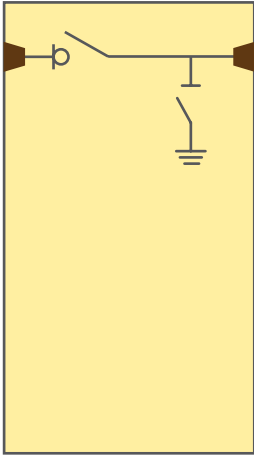

Single Line

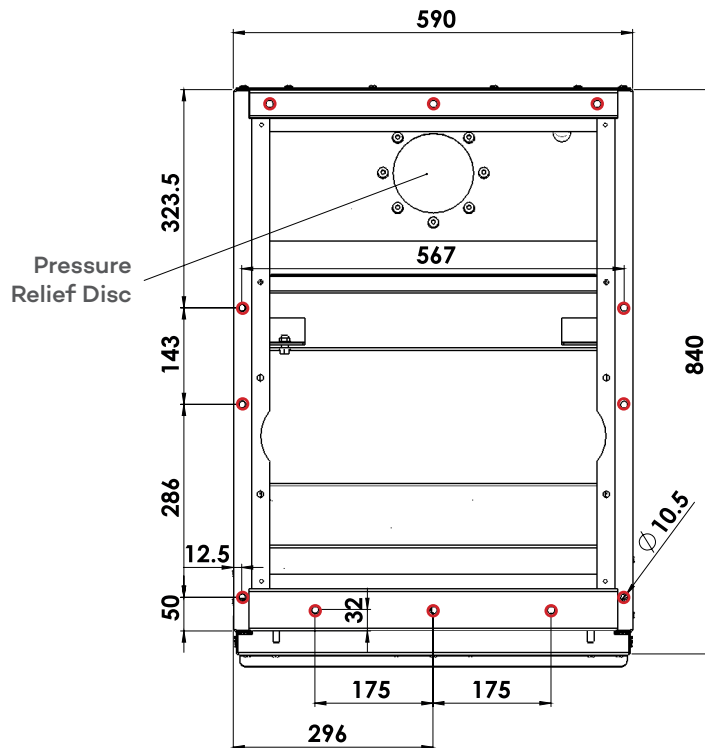
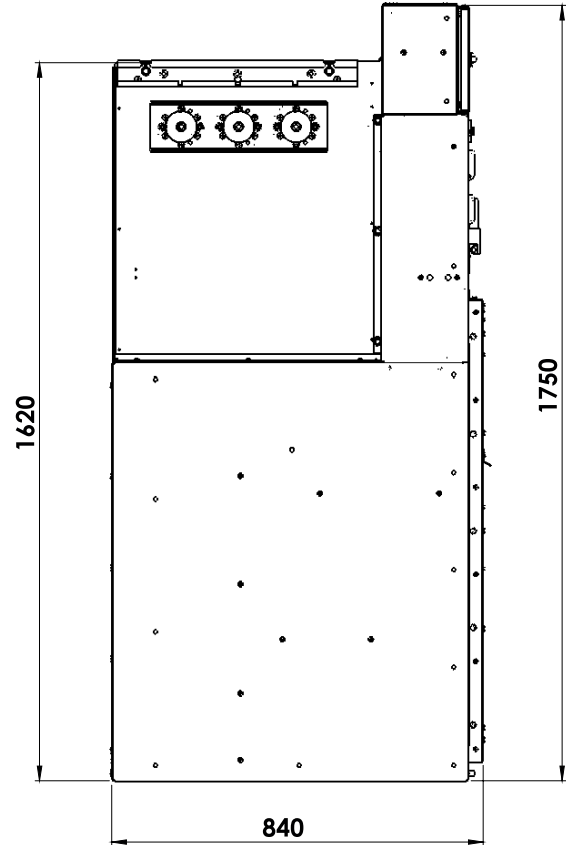
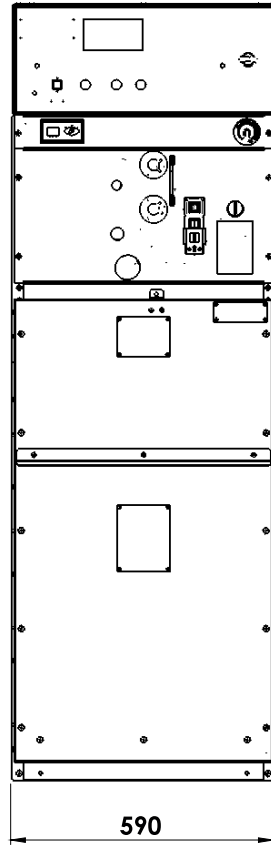

○ Fixing points

▲ Front

▼ Rear

○ CUBICLE WITH BUS BAR COUPLING SFA-RM36.C

▲ 06

M[S] METERING (CT+VT) GROUP WITH SWITCH-DISCONNECTOR SFA-RM36.M[S]

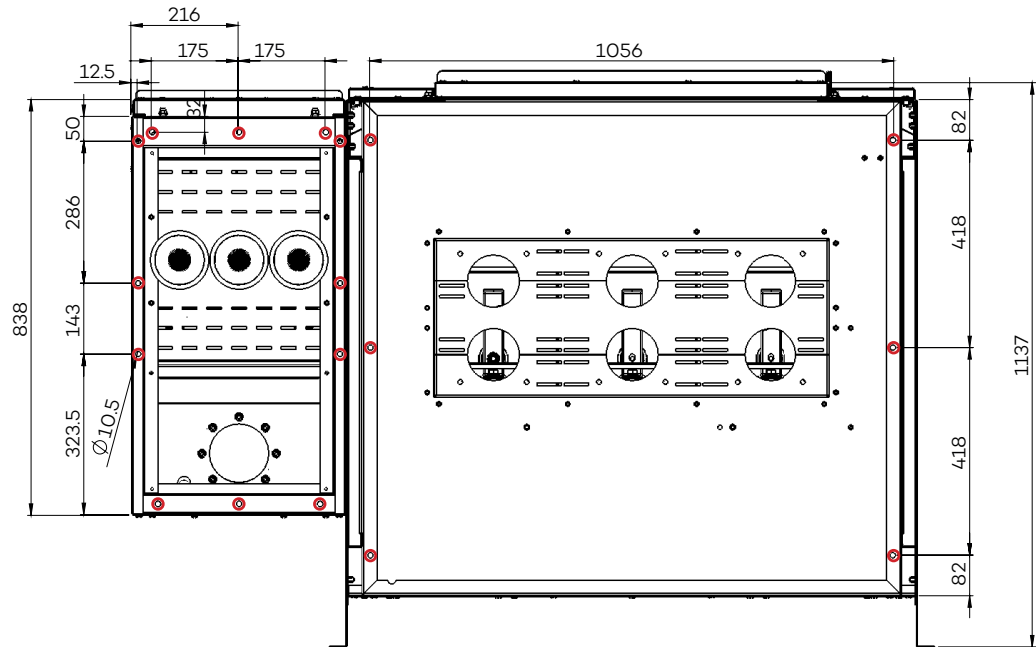
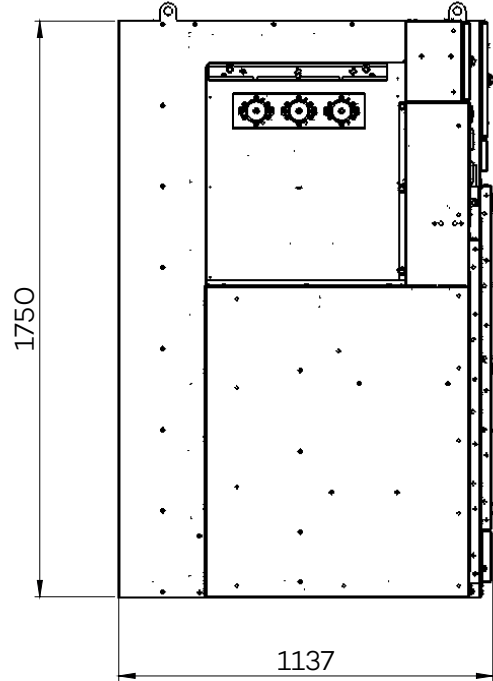
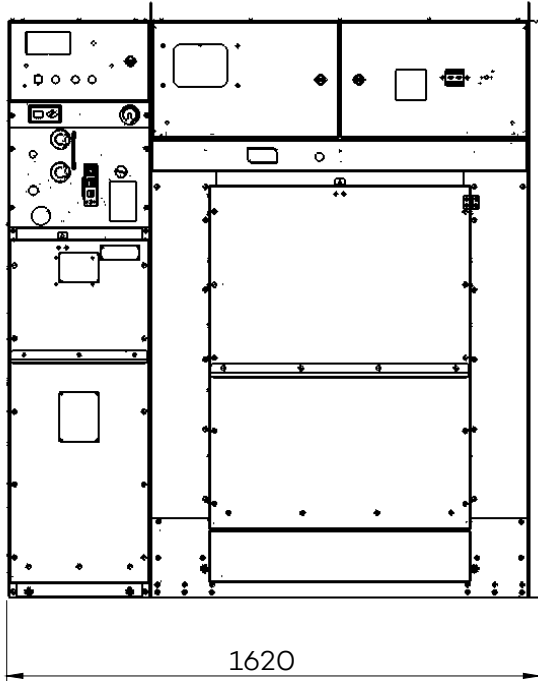

Single Line

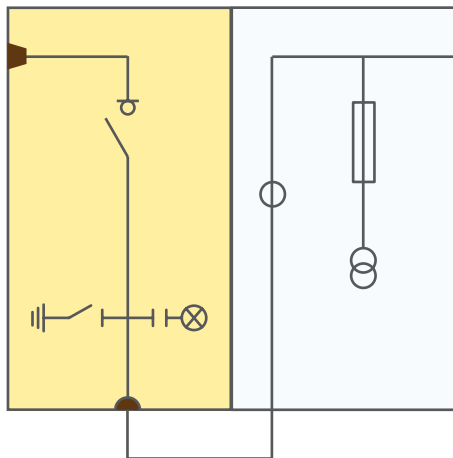

- Fixing points
- ▲ Front
- ▼ Rear

DIMENSIONS, SINGLE LINE DIAGRAMS AND VIEWS

08. METERING (CT+VT) CUBICLE WITH VACUUM CIRCUIT BREAKER

[SFA-RM36.M[B]

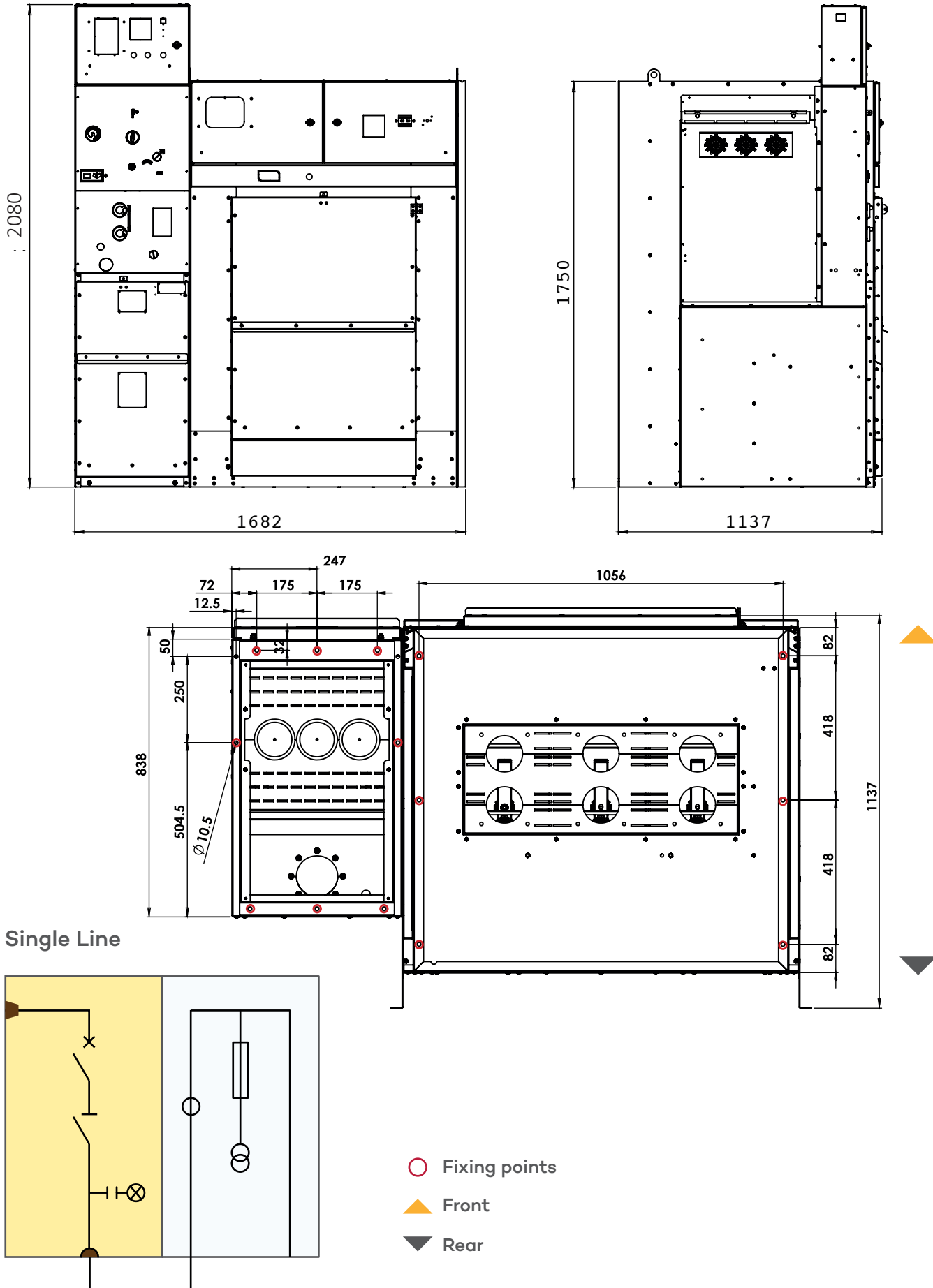

METERING (CT+VT) GROUP WITH VACUUM CIRCUIT BREAKER **SFA-RM36.M[B]**

08

DIMENSIONS, SINGLE LINE DIAGRAMS AND VIEWS

**09. METERING (CT+VT) CUBICLE WITH SWITCH-FUSE COMBINATION
[SFA-RM36.M[F]**

M[F] METERING (CT+VT) GROUPE WITH SWITCH-FUSE COMBINATION SFA-RM36.M[F]

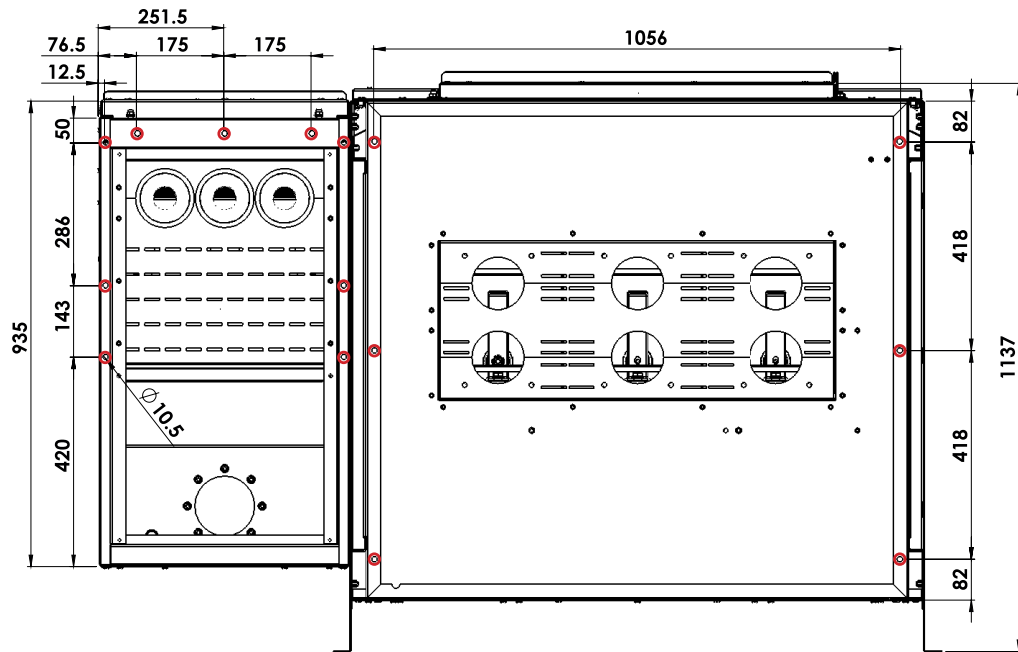
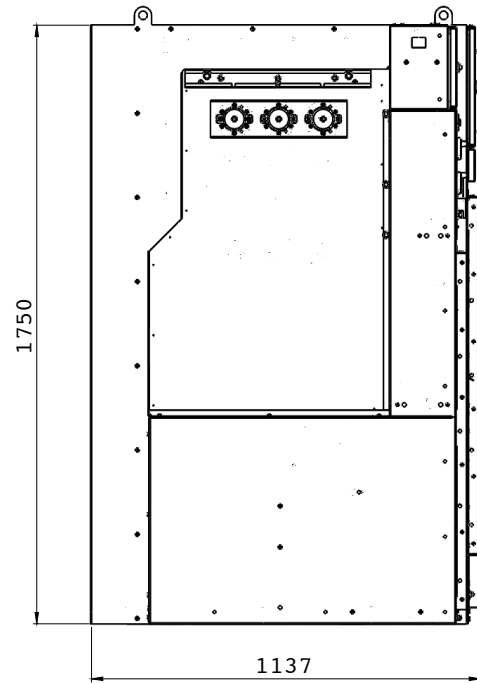
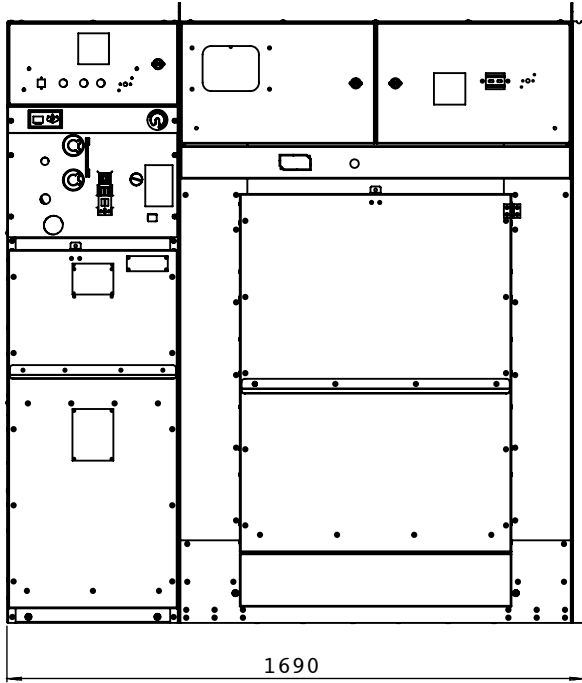

Single Line

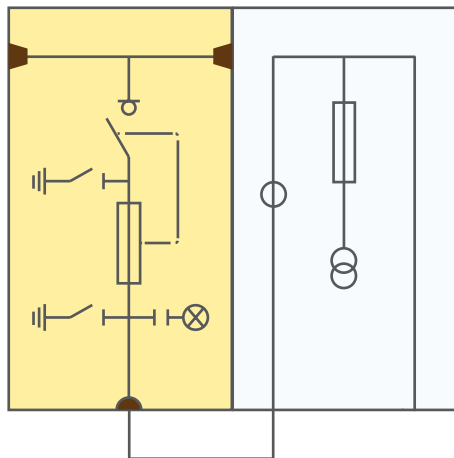

- Fixing points
- ▲ Front
- ▼ Rear

DIMENSIONS, SINGLE LINE DIAGRAMS AND VIEWS

10. VOLTAGE METERING CUBICLE WITH SWITCH-DISCONNECTOR
[SFA-RM36.V[S]

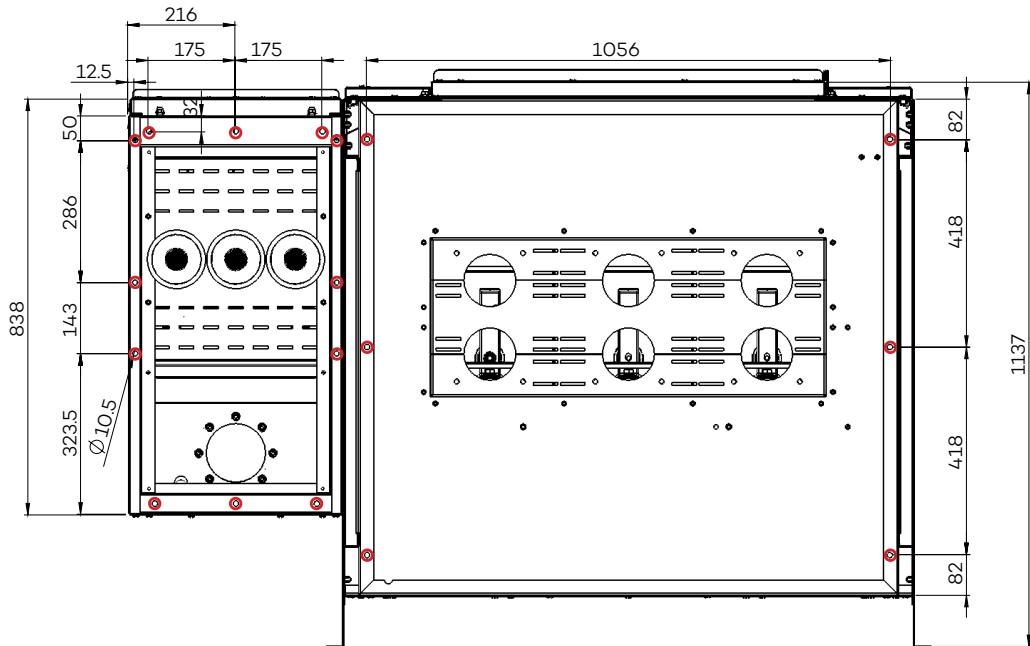
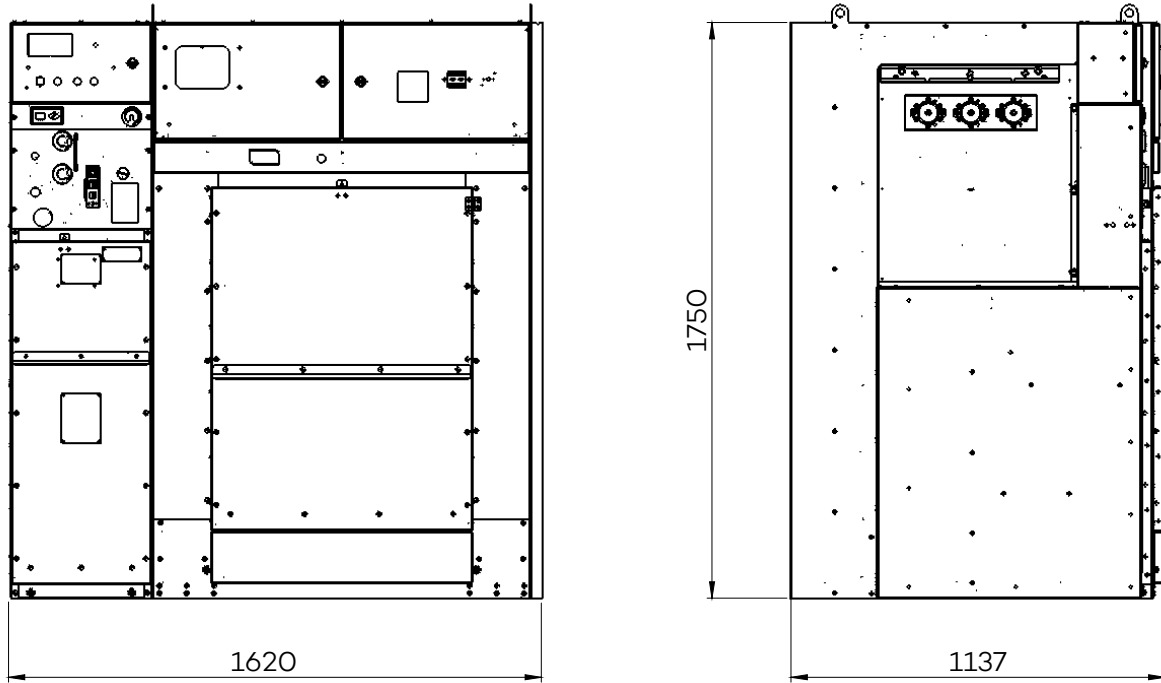

Single Line

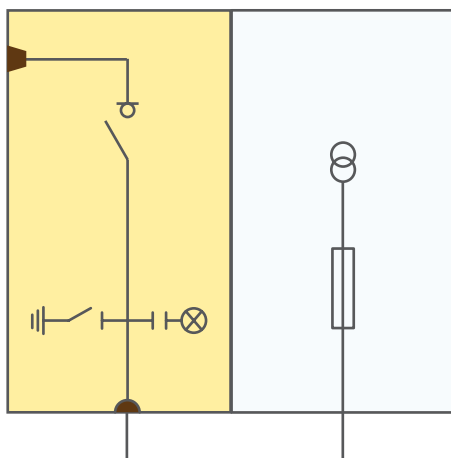

- Fixing points
- ▲ Front
- ▼ Rear

VOLTAGE METERING CUBICLE WITH SWITCH-DISCONNECTOR SFA-RM36.V[S]

V[S]
10

11. CABLE RISING CUBICLE [SFA-RM36.CR]

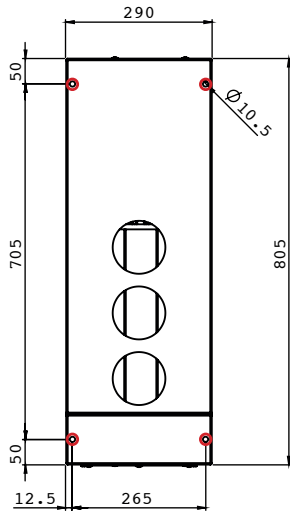
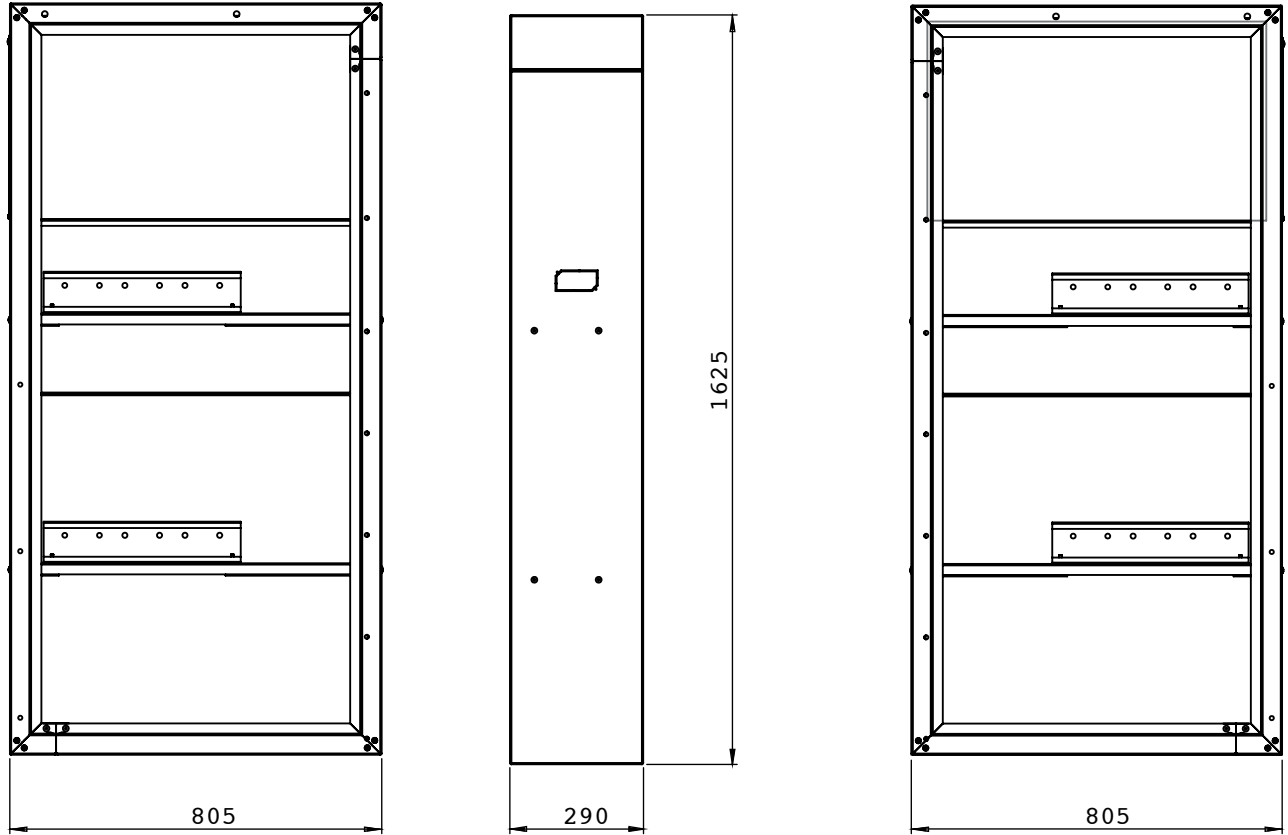

○ Fixing points

Single Line

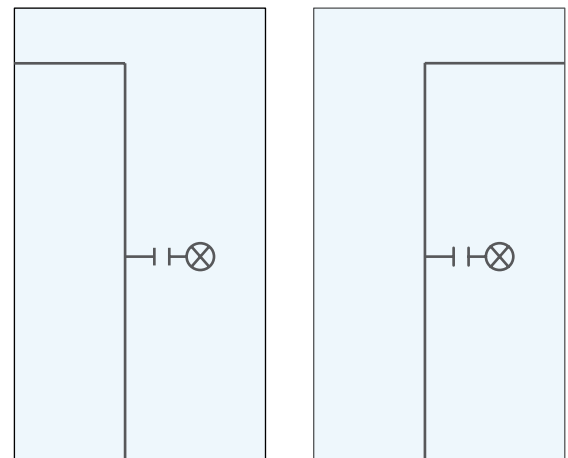

DIMENSIONS, SINGLE LINE DIAGRAMS AND VIEWS

12. CUBICLE WITH VACUUM CIRCUIT BREAKER (CT+VT)

SFA-RM36.B[CV]

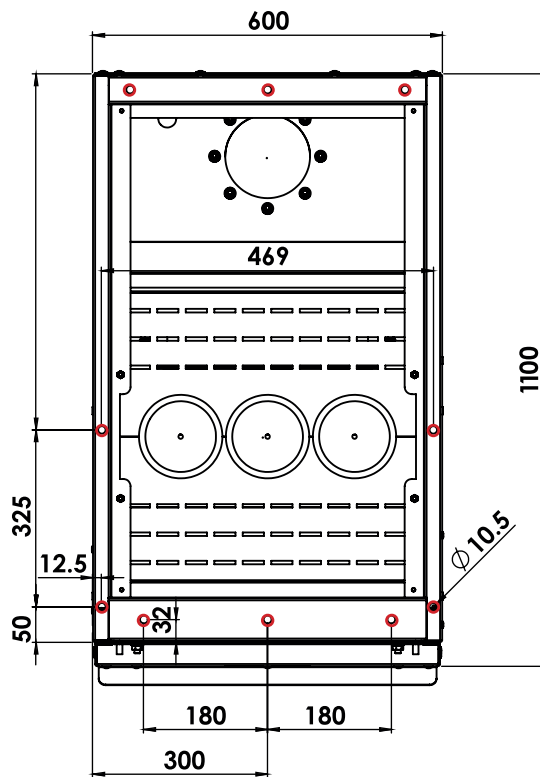
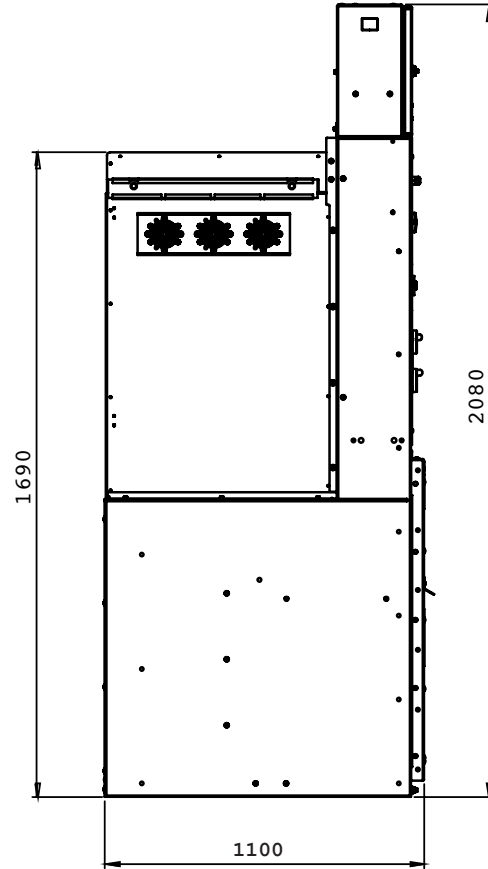
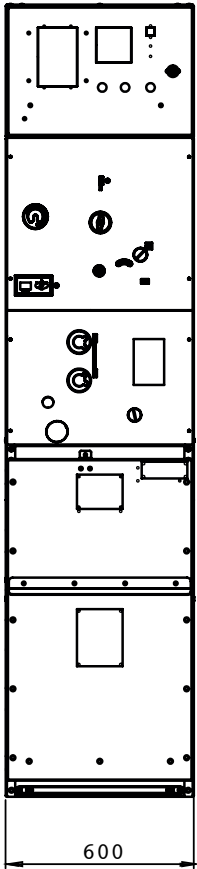

○ Fixing points

▲ Front

▼ Rear

CUBICLE WITH VACUUM CIRCUIT BREAKER EQUIPPED WITH CT+VT SFA-RM36.B[CV]

B[CV]

12

Single Line

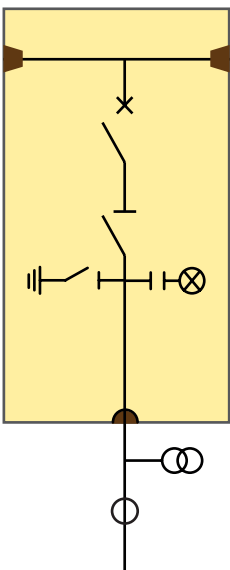

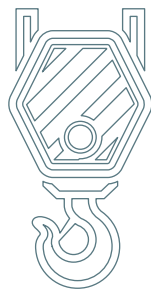
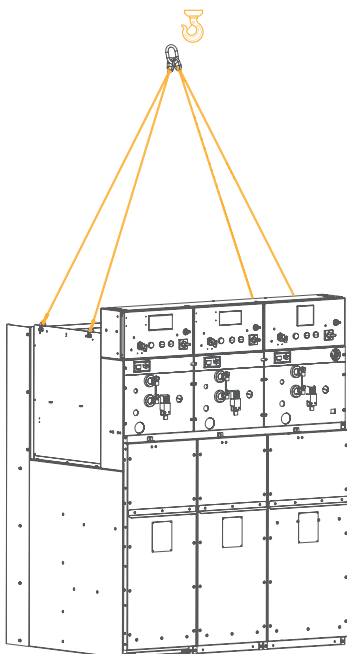
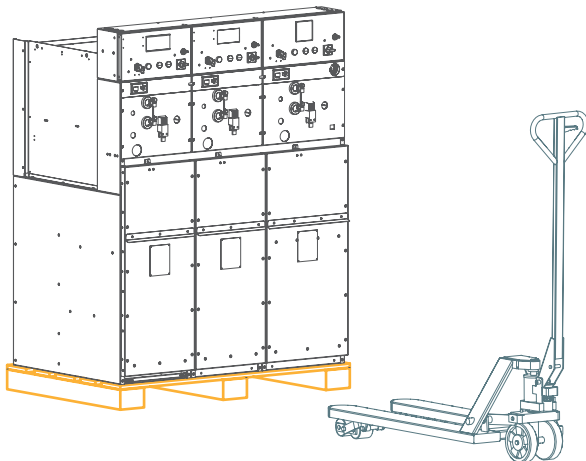
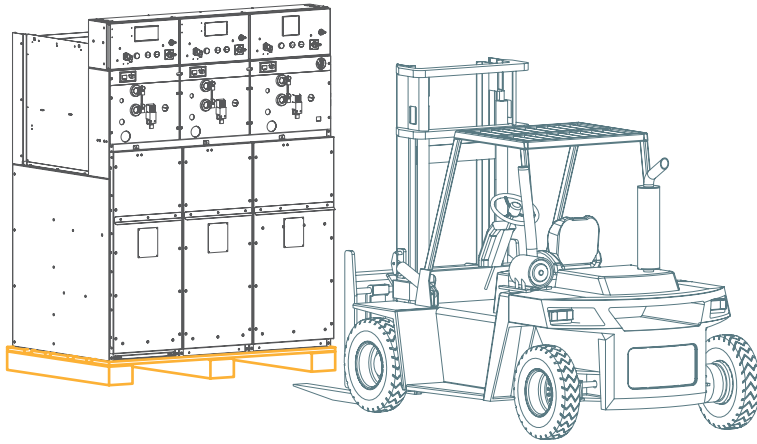
**PACKING:**

Unless otherwise is stated;

- **For railway and highway transportation;** cubicle is fixed on the wooden pallets and covered with plastic.
- **For air and sea transportation;** cubicles are packed by using shrink-wrap in wooden crate and put desiccant bags against humidity.

HANDLING:

- Package can be transported with lifted truck or forklift truck (for only with pallet)

**WARNING!**

- Never tip the crates over.
- Avoid slipping and tilting

STORAGE:

The followings should be recommended for a smooth storage;

- Keep the equipment in its original package during the storage,
- The storage area should be protected against rain, water, water vapor, saline atmosphere and pollution.
- Storage area temperature is advised not below than -25 C
- altında olmamalıdır.

Crane transport with lifting eyes:

Cubicles can be lifted and transported by four lifting eyes at the top. Be sure that lifting capacity of the rope is proper for the weight of the cubicle.

Before installation on site;

- Be sure that there is no damage on the equipment during the transportation,
- Be sure that the indicator of the SF6 Gas Manometer is on the GREEN area.
- Be sure that there is no any missing parts of the cubicle. (Operating handle, extension kits, etc.)

SFA-RM36 cubicles should be installed indoor.



A	B	C
Maximum 50 mm	50 mm	640 mm (± 25)



WARNING!

- The floor to be fixed on should be well-levelled. Other wise cover of the compartment does not work properly and some failiures may occur on the extension bar.
- The distances to rear and side walls should be taken into consideration.

SFA-RM36 type SF₆ Gas Insulated Switchgears have been designed and developed in the R&D Center of SFA ELECTRIC.

Special features to SFA-RM36;

- Lower SF₆ Gas Filling Pressure (1,10 bar/abs.)
- Lower Minimum Operating Pressure (1,05 bar/abs.)
- Lower Gas Leakage Ratio (<%1/year)
- The visibility of the earthing switch contact position from outside of the cubicle.

Stainless steel tank; filled with SF₆ gas, is sealed to the atmosphere with "Sealed Pressure" method.

Gas tightness test is done for every and each unit as a routine test. Helium is used as tracer gas during the leakage test. Leakage test and SF₆ gas filling are fulfilled inside the vacuum chamber.

Expected life is more than 30 years for SFA-RM36 RMU's.

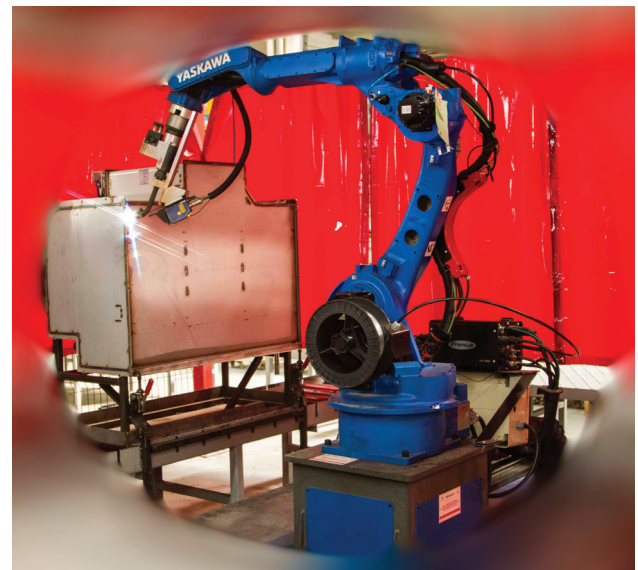

Welding robot have been used for stainless steel tank welding. With this method, it is aimed to minimize production errors caused by human factor.

QUALITY CONTROL:

Type tests of SFA-RM36 were carried out in the accredited Labs.

Following routine tests are applied to each units.

- Power frequency withstand test,
- Measurement of the resistance of the main circuit,
- Gas leakage test,
- Mechanical operating test,
- Visual controls,
- Electrically functional tests

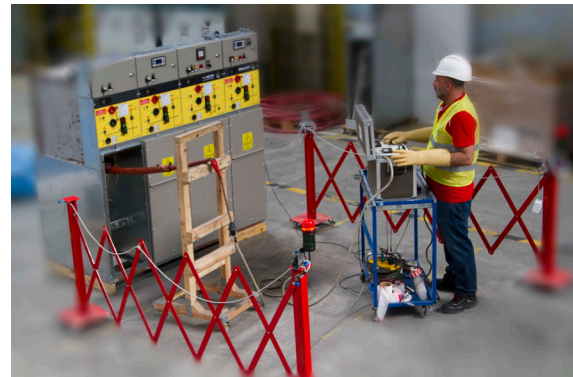

QUALITY MANAGEMENT SYSTEM:

All products in SFA ELECTRIC have been manufactured under well-defined Quality Systems and procedures applied to all departments.

Conformity of the production with Quality Management Systems is certified by Bureau Veritas.

<p>ISO 9001</p> <p>BUREAU VERITAS Certification</p>		<p>ISO 14001</p> <p>BUREAU VERITAS Certification</p>		<p>OHSAS 18001</p> <p>BUREAU VERITAS Certification</p>	
--	---	---	--	---	---

ISO 9001:2015
 Quality Management System

ISO 14001:2004
 Environmental Management System

OHSAS 18001
 Worker's Health and Work Safety

FEEDER WITH SWITCH-DISCONNECTOR (General)

Rated Voltage	kV	36
Rated normal current (main busbar)	A	630
Rated power frequency withstand voltage		
§ Phase to earth, between the phases	kV-etken	70
Across the isolating distance	kV-etken	80
Rated lightning impulse withstand voltage		
§ Phase to earth, between the phases	kV-tepe	170
Across the isolating distance	kV-tepe	195
Rated frequency	Hz	50
Rated short-time withstand current	kA	16;21
Duration of short-circuit	s	1;3
Rated filling level for insulation	bar (Mpa)	1,1 (0,110) (abs)
Minimum functional level for insulation	bar (Mpa)	1,05 (0,105) (abs)
Internal arc classification (IAC)		A (FL) 16 kA-1s
Loss of the Service Continuity		LSC 2
Mechanical Impact Class (IK)	Joule	IK10 (20J)
Protection Class (IP)		
* Switching Compartment		IP 67
* HV Cable Connection Compartment		IP 2X
* Mechanism Compartment		IP20
* LV Panel Compartment		IP30

SWITCH-DISCONNECTOR

Type of switch		General, Three phase, three positioned (OPEN-CLOSE-EARTH) switch-disconnector
Type		SFA-RM-630A - 16kA LBS
Rated normal current	A	630
Rated short-circuit withstand current and duration	kA	16 kA-1s
Rated peak withstand current	kA-peak	40
Short -circuit making current (peak)	kA-peak	40
Electrical endurance class		E3
Mechanical endurance class		M1

EARTHING SWITCH

Type of switch		SFA-RM-16kA ES
Rated short-circuit withstand current and duration	kA	16 kA-1s
Rated peak withstand current	kA-peak	16
Short –circuit making current (peak)		40
Electrical endurance class		E2
Mechanical endurance class		M1

NORMAL SERVICE CONDITIONS

Ambient temperature		
* Maximum	° C	40
* Average	° C	35
* Minimum	° C	-25
Indoor/Outdoor Installation		Indoor/outdoor*
Altitude		up to 2000 m
Relative humidity		maximum % 96

* Get in contact with SFA ELECTRIC for OUTDOOR solution

FEEDER WITH SWITCH+FUSE COMBINATION (General)

Rated Voltage	kV	36
Rated normal current (main busbar)	A	630
Rated power frequency withstand voltage		
§ Phase to earth, between the phases	kV-rms	70
Across the isolating distance	kV-rms	80
Rated lightning impulse withstand voltage		
§ Phase to earth, between the phases	kV-peak	170
Across the isolating distance	kV-peak	195
Rated frequency	Hz	50
Rated short-time withstand current	kA	16
Duration of short-circuit	s	1
Rated filling level for insulation	bar (Mpa)	1,1
Minimum functional level for insulation	bar (Mpa)	1,05
Internal arc classification (IAC)		A (FL) 16 kA-1s
Loss of the Service Continuity		LSC 2
Mechanical Impact Class (IK)	Joule	IK07 (2J)
Protection Class (IP)		
* Switching Compartment		IP 67
* HV Cable Connection Compartment		IP20
* HV Fuse Compartment		
* Mechanism Compartment		IP20
* LV Panel Compartment		IP30
Rated Transfer Current	A	470

SWITCH-DISCONNECTOR

Type of switch		General, Three positioned (OPEN-CLOSE-EARTH) switch-disconnector
Type		SFA-RM-630A - 16kA LBS
Rated normal current	A	200
Rated short-circuit withstand current and duration	kA	16 kA-1s
Rated peak withstand current	kA-peak	40
Short -circuit making current (peak)	kA-peak	40
Electrical endurance class	E3	E3
Mechanical endurance class	M1	M1

EARTHING SWITCH (on up-stream side)

Type		SFA-RM-16kA ES
Rated short-circuit withstand current and duration	kA	16 kA-1s
Rated peak withstand current	kA-peak	16
Short -circuit making current (peak)		40
Electrical endurance class		E2
Mechanical endurance class		M1
Electrical endurance class		E3
Mechanical endurance class		M1

EARTHING SWITCH (on down-stream side)

Type		SFA-RM-1kA ES
Rated short-circuit withstand current and duration	kA	1 kA-1s
Rated peak withstand current	kA-peak	2,5
Short -circuit making current (peak)		2,5
Electrical endurance class		E2
Mechanical endurance class		M1

NORMAL SERVICE CONDITIONS

Ambient temperature		
* Maximum	° C	40
* Average	° C	35
* Minimum	° C	-25
Indoor/Outdoor Installation		Indoor/outdoor*
Altitude		up to 2000 m
Relative humidity		maximum % 96

* Get in contact with SFA ELECTRIC for OUTDOOR solution

FEEDER WITH VACUUM CIRCUIT BREAKER (Genel)

Rated Voltage	kV	36
Rated normal current (main busbar)	A	630
Rated power frequency withstand voltage		
§ Phase to earth, between the phases	kV-rms	70
Across the isolating distance	kV-rms	80
Rated lightning impulse withstand voltage		
§ Phase to earth, between the phases	kV-peak	170
Across the isolating distance	kV-peak	195
Rated frequency	Hz	50
Rated short-time withstand current	kA	16; 21
Duration of short-circuit	s	1; 3
Rated filling level for insulation	bar (Mpa)	1,1 (0,110) (abs.)
Minimum functional level for insulation	bar (Mpa)	1,05 (0,105) (an
Internal arc classification (IAC)		A (FL) 16 kA-1s
Loss of the Service Continuity		LSC 2
Mechanical Impact Class (IK)	Joule	IK10 (20J)
Protection Class (IP)		
* Switching Compartment		IP 67
* HV Cable Connection Compartment		IP20
* Mechanism Compartment		IP20
* LV Panel Compartment		IP30

VACUUM CIRCUIT BREAKER

Vacuum Interrupter		EATON
Rated normal current	A	630
Rated short-circuit breaking current	kA	16
Rated short-circuit withstand current and duration	kA	16 kA-1s
Rated peak withstand current	kA-peak	40
Short-circuit making current (peak)	kA-peak	40
Rated Operating Sequence		O-0.3 s -CO-3 min-CO
Electrical endurance class		E2
Mechanical endurance class		M1
Capacitive breaking current class		C2

DISCONNECTOR

Type		36BV-0000
Rated normal current	A	630
Rated short-circuit withstand current and duration	kA	16 kA-1s
Rated peak withstand current	kA-peak	16
Electrical endurance class		E0
Mechanical endurance class		M1

EARTHING SWITCH

Type		SFA-RM-16kA ES
Rated short-circuit withstand current and duration	kA	16 kA-1s
Rated peak withstand current	kA-peak	40
Short -circuit making current (peak)		40
Electrical endurance class		E2
Mechanical endurance class		M1

NORMAL SERVICE CONDITIONS

Ambient temperature		
* Maximum	°C	40
* Average	°C	35
* Minimum	°C	-25
Indoor/Outdoor Installation		Indoor/outdoor*
Altitude		up to 2000 m
Relative humidity		maximum % 96

* Get in contact with SFA ELECTRIC for OUTDOOR solution

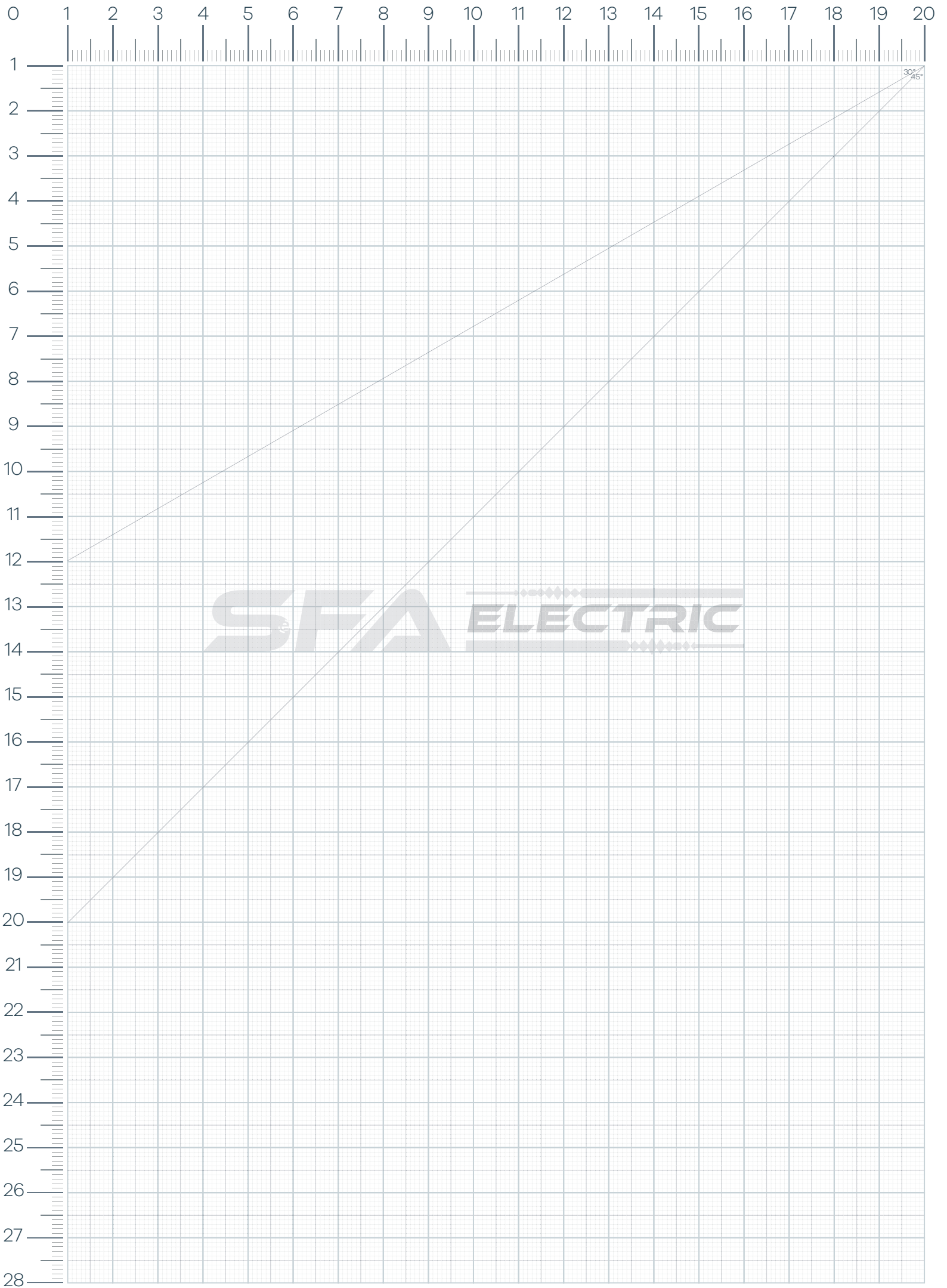

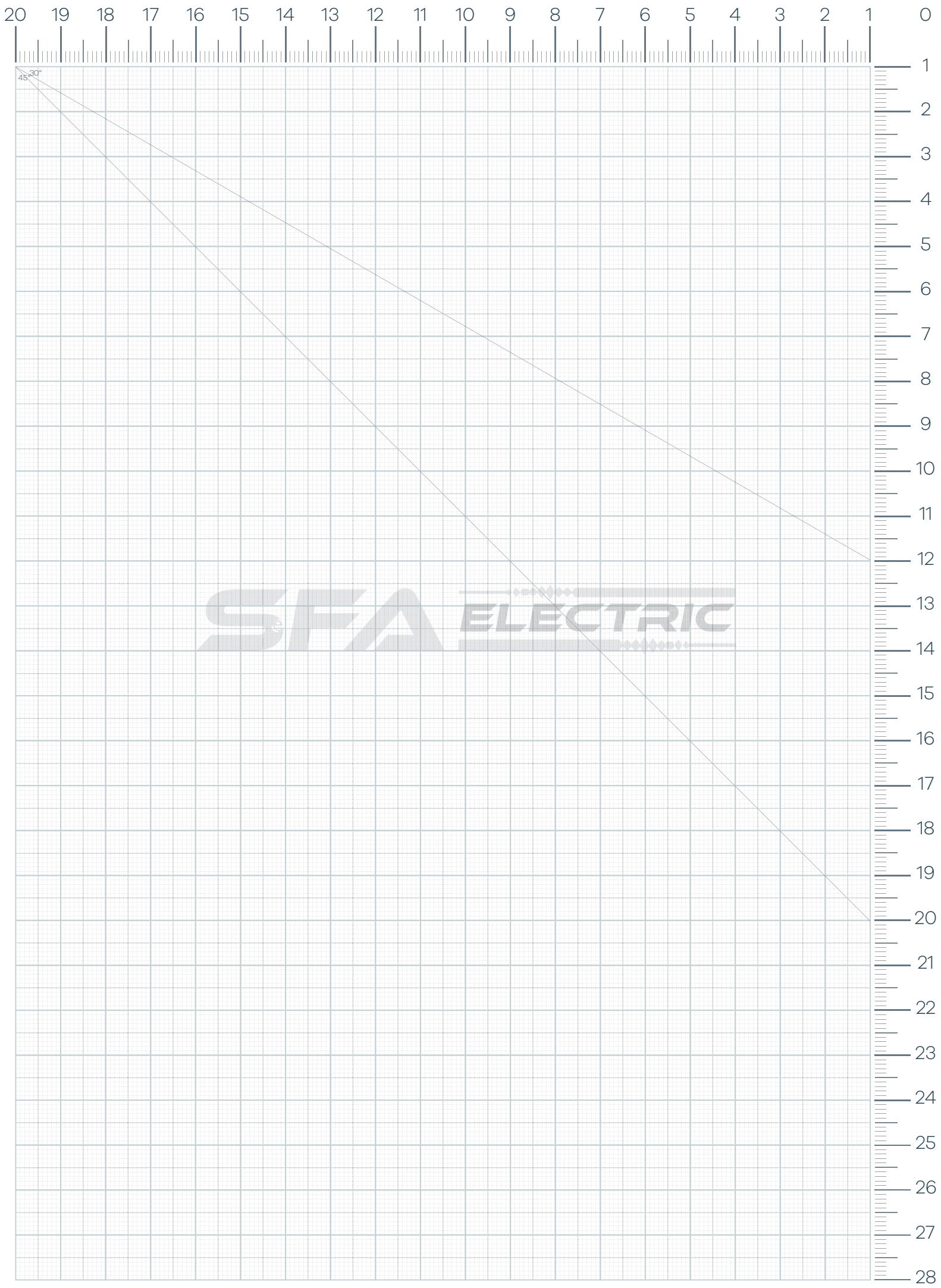

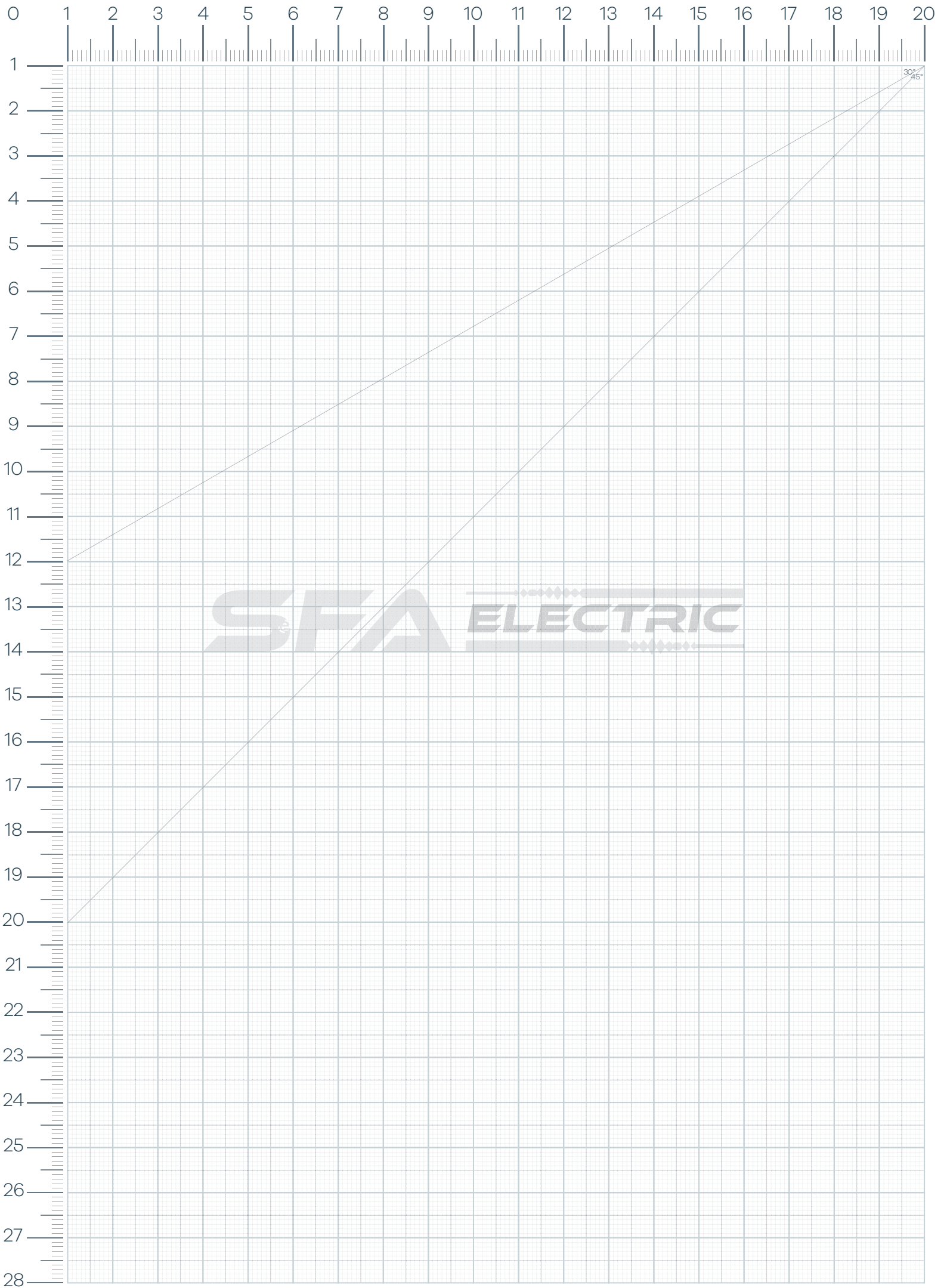

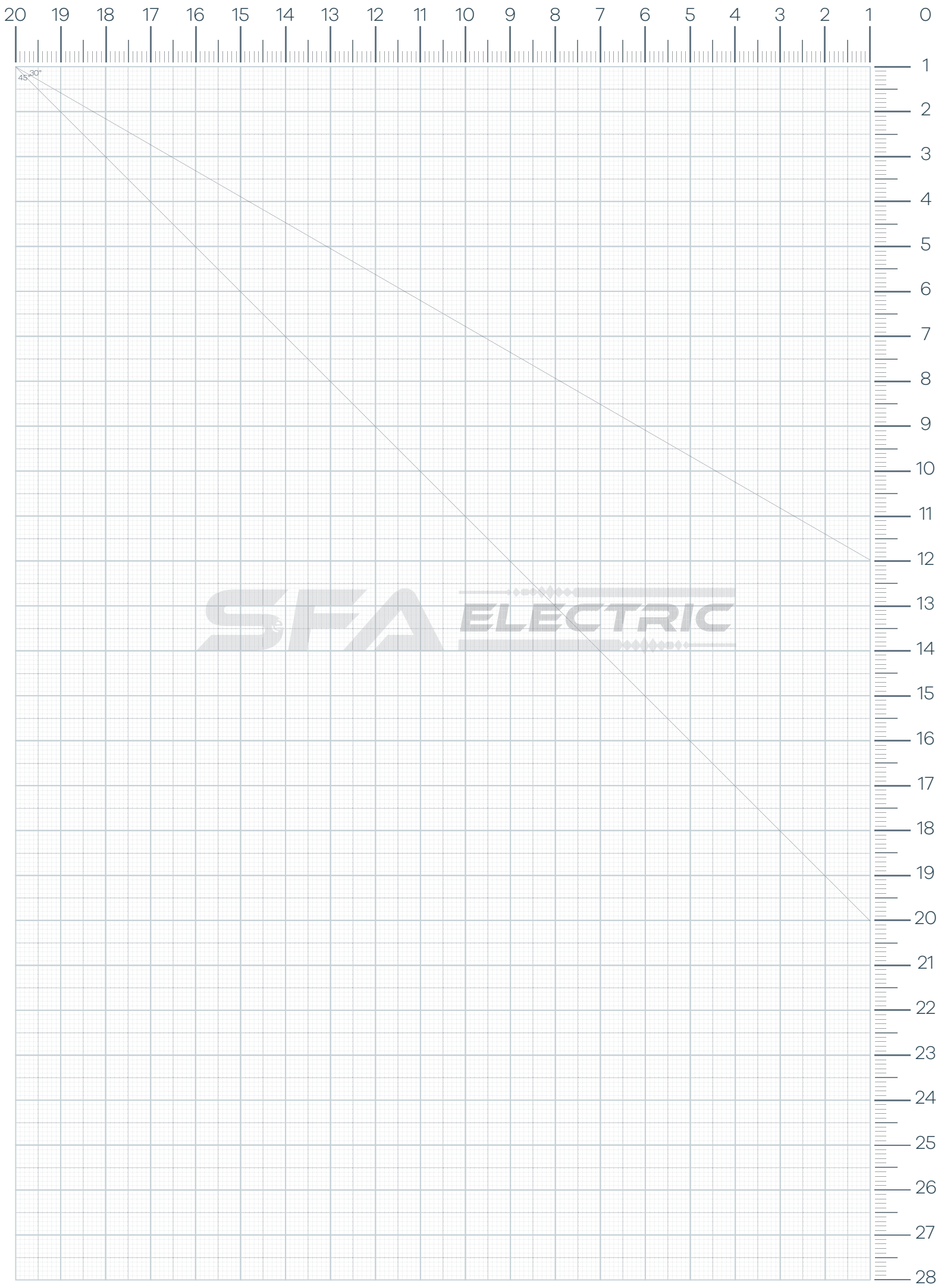

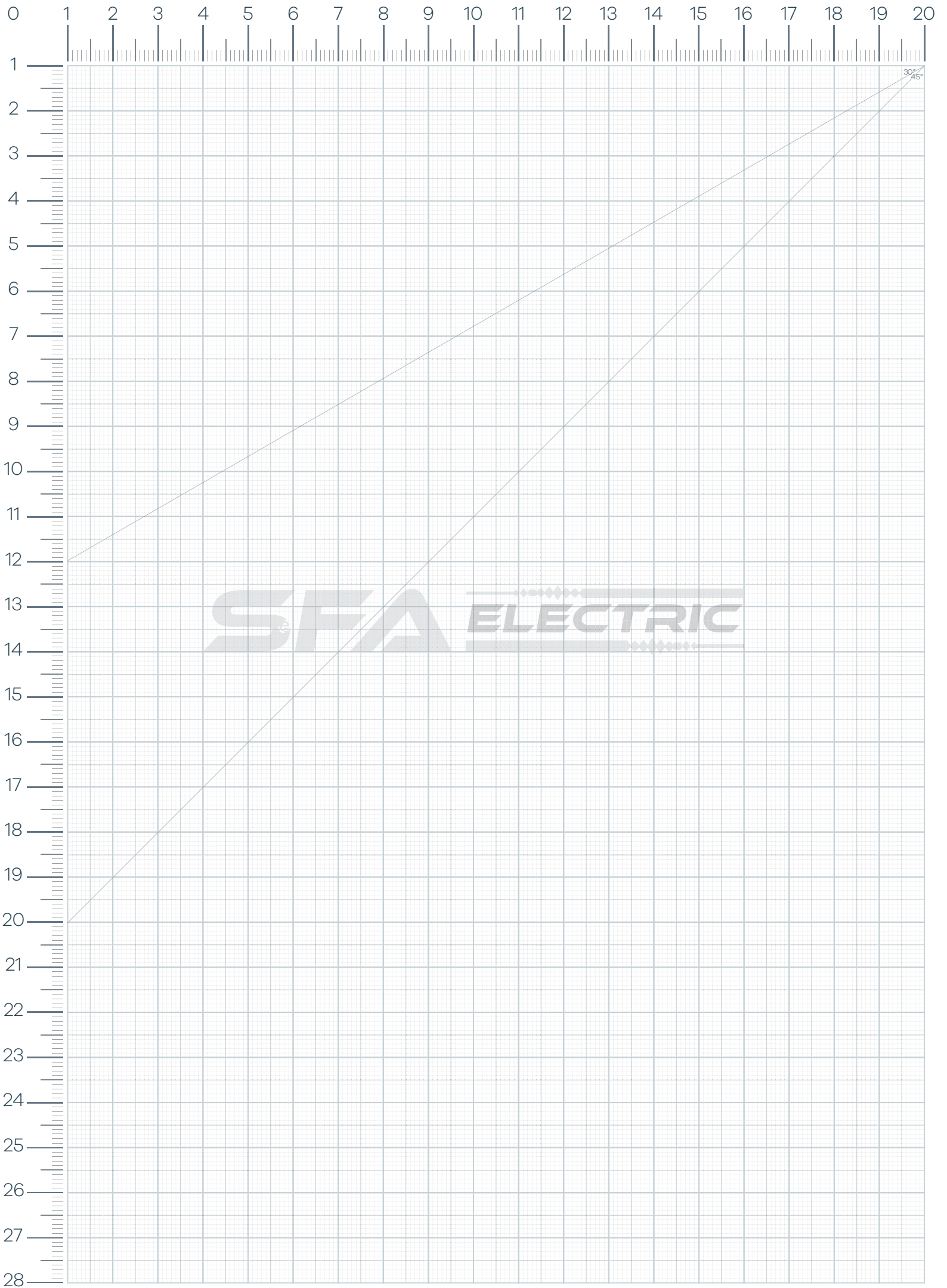

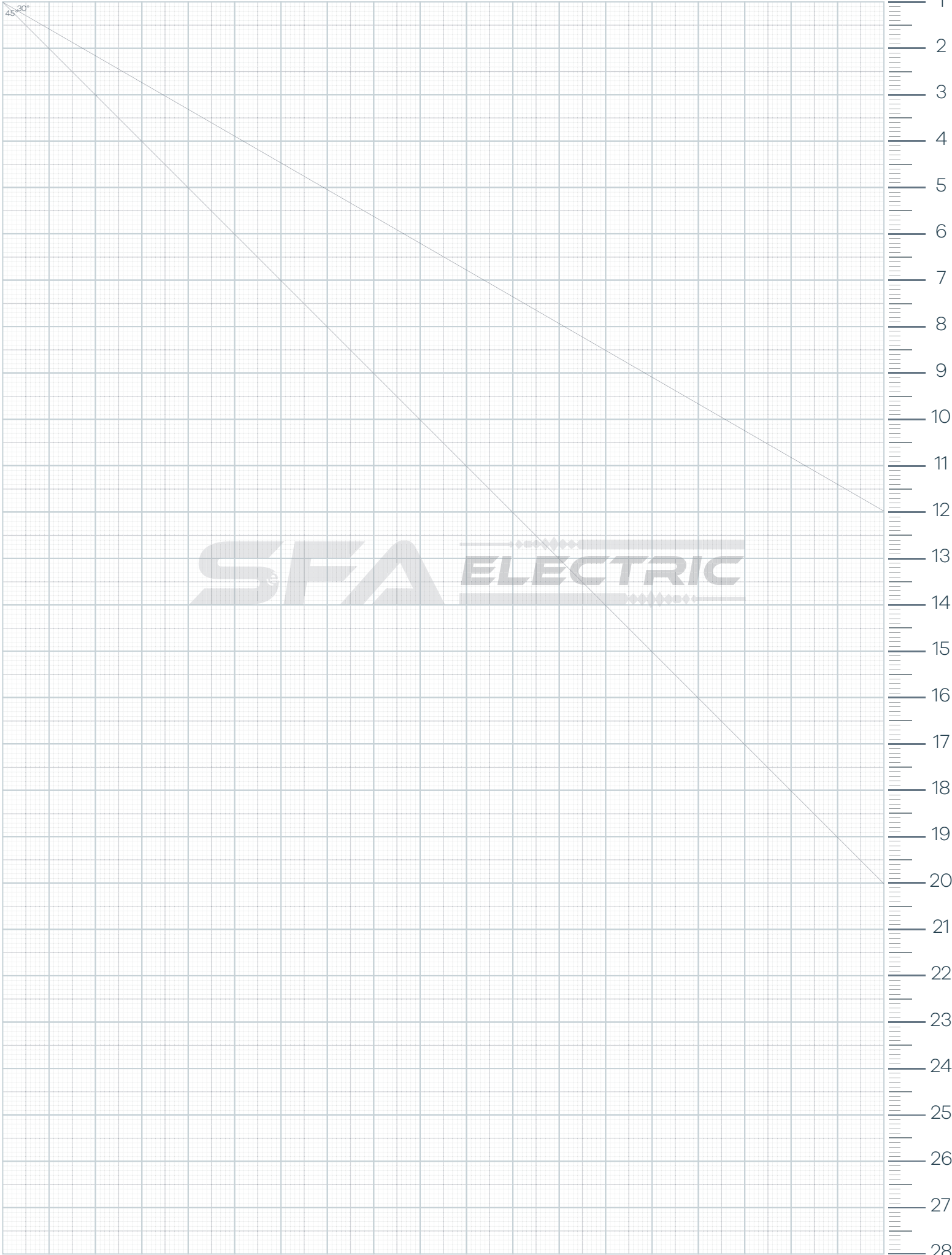

SFA **ELECTRIC**

SFA ELECTRIC

1. Organize Sanayi Bölgesi 5. Kısım Oğuz Caddesi No:52
Sincan - ANKARA / TURKEY

T. +90.312.267 1576

www.sfaelectric.com



All rights reserved. No part of this catalog covered by copyrights
may be reproduced in any form or by any means without
permission of the copyright holder.

Only reproduction of this document is authorized with the written
permission from SFA Electric.